

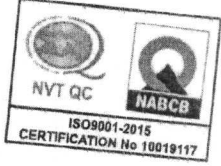

हिंदी केवल एक भाषा नहीं बल्कि हमारी राष्ट्रीय पहचान है।



आईटीआई लिमिटेड  
नेटवर्क सिस्टम्स यूनिट  
सामग्री प्रबंधन विभाग  
एफ - 100, पश्चिम विंग  
दूरवाणीनगर, बेंगलूरु - 560 016, भारत  
फोन : +91 (80) 2566 0508  
ई.मेल : materials\_nsu@itilttd.co.in  
ISO 9001 : 2015 प्रमाणित युनिट

**ITI LIMITED**

Network Systems Unit  
Materials Management Dept.  
F-100, West Wing  
Doorvaninagar, Bengaluru - 560 016, India  
Tel : +91 (80) 2566 0508  
E-mail : materials\_nsu@itilttd.co.in  
ISO 9001:2015 Certified Unit

ITI Web-Site/ Govt. Portal

**ENQUIRY**

**NSU 5G 51Y/II**

DATE 06 05 2026

Dear Sir / Madam, please quote your best price and delivery for supply of the following item/s,

SL. NO.	Item Description as per Technical Specifications	QTY	Unit
1	<b>Tender for "Selection of Partners for Aerial OFC and laying of OFC by the way of Trenching, Duct laying, Blowing/Pulling of OFC Cable in 02 districts of West Bengal for Bharat Net Ph-3 Network Project"</b>		As per Tender Document
Enls: Annexure A: General Terms and Conditions Annexure B: Tender Document		Annexure C: Price Bid Format	
Tender Due Date	16.05.2026, 14.00 Hrs.	Tender Opening Date	16.05.2026, 15.00 Hrs.
Tender Opening Venue	Materials Management Dept., N.S. Unit, I.T.I. Ltd., Dooravaninagar, Bengaluru- 560 016 (ITI tender wizard)		
Terms of Payment (TOP)	As per the tender document : ITI/NSU/BN3/WB-Z2/T&D Dated 06.05.2026		
Delivery and penalty	As per the tender document : ITI/NSU/BN3/WB-Z2/T&D Dated 06.05.2026		
Compliance	Point-wise compliance to each item/ Clause mentioned in Tender Document.		
Validity of the offer	180 days from Tender Opening date.		
PBG	The successful bidders shall submit PBG from a schedule bank to ITI for an amount equivalent to 5% of the Purchase Order Value/ Work Order Value/LOI (incl. GST), valid for a period of 18 months plus 60 days within 15 days from date of issue of LOI.		
Earnest Money Deposit & Tender Fee	EMD as per the tender document Ref No: ITI/NSU/BN3/WB-Z2/T&D Dated 06.05.2026 to be submitted & Tender fee of Rs 11,800/-. MSEs exempted from EMD & tender fee but should submit bid securing declaration form.		
Other terms and conditions	As per Enquiry NSU5G51Y/II dated 06.05.2026		
<p><b>Note: Offers should be submitted online as per tender documents.</b>  <b>For submission of online Bid &amp; Procedure to be followed visit</b>  <a href="https://itilimited.ewizard.in/">(https://itilimited.ewizard.in/)</a>  <b>All Vendors have to register in website &amp; pay the tender processing fee if required: (https://itilimited.ewizard.in/) for submitting online BID.</b></p>		<p>For ITI Ltd., N S Unit,</p> <p><i>[Signature]</i>  <b>Additional General Manager-MM(NS)</b></p>	

पंजीकृत एवं निगमित कार्यालय : आईटीआई भवन, दूरवाणीनगर, बेंगलूरु - 560 016, भारत फोन :+91 (080) 2561 4466, फैक्स : +91 (080) 2561 7525  
Registered & Corporate Office : ITI Bhavan, Doorvaninagar, Bengaluru - 560016, India Phone: +91 (080) 2561 4466, Fax: +91 (080) 2561 7525  
TIN : 29980058837 GSTIN : 29AAAC14625C2ZU CIN : L32202KA1950GOI000640 Visit our Website : www.itilttd.in



## GENERAL TERMS AND CONDITIONS FOR SUBMISSION OF TENDER (INLAND)

ENCLOSURE TO ENQUIRY No. NSU5G51Y/ II : Dated 06.05.2026

### 1. PRICES:

- (a) ITI Ltd., is planning to have long term tie up with limited vendors, who can supply the item with good quality, prompt delivery and at lowest price. Hence, you may quote in such a way that a long-term relationship is possible.
- (b) Prices must be per unit as called for in the enquiry and should be on FOR ITI/FOR destination basis as the case may be and inclusive of Insurance charges.
- (c) ITI Ltd., under normal circumstances, may not negotiate for the price. Hence you are requested to quote your best price in the original quotation itself.
- (d) Any counter terms and conditions are not binding on us unless ITI Ltd., agree to the same in writing.
- (e) In case of an order issued on you, the ordered rate should be firm till the completion of the order. In case where the market prices are going down beyond 5% of the ordered rate or decrease in the statutory levies, the same should be passed on to ITI Ltd.
- (f) Vendors should deliver the materials to ITI Ltd., Stores/the destination as mentioned in the P.O. ITI Ltd., will not take the responsibility of clearing the goods from the carriers godown/office/Railway Station/Airport, etc.
- (h) If the supplier supplies the same item at a lower rate to any of their customers during the pendency of execution of ITI Ltd., Purchase Order/ Order Amendment, the supplier should voluntarily come forward and reduce the price.
- (i) The validity of your offer should be for a minimum period of **180** days from the date of opening the tender.
- (j) Any Plant/division of ITI reserves the right for placement of Repeat Order if required within one year of original PO date.

### 2. TERMS OF PAYMENT: :( As per Enquiry: NSU5G51Y/ II)

- (a) Payment will be made for the accepted quantity/services as per Main sheet of NSU5G51Y/ II
- (b) No payment will be made for the rejected quantity.

### 3. INSPECTION: :( As per Enquiry: NSU5G51Y/ II)

- (a) ITI reserves the right to split the purchase order among the vendors who are capable of meeting the Quality, Delivery and Cost requirements. Preference will be given to the vendors with well-maintained and proven Quality Assurance.
- (b) We are planning to reduce inspection time with self-certification scheme for the vendors who keep up good quality leading to "ship to stock system".
- (c) Inspection of the material at our works/site will be final. ITI reserves the right to inspect the material at any other standard testing centre authorised by us.
- (d) We or our representative including our customer may if required preliminarily inspect the product at vendor's premises. Such verification shall not absolve the vendor of the responsibility to provide the acceptable product nor shall preclude subsequent rejection during the final inspection at our works/site. It is the responsibility of every vendor to ensure that only the inspected materials conforming to our specifications / drawings / requirements are supplied.
- (e) The supplies shall be from the latest batch of production. Batch Number should be indicated on the item/ packet / test certificate and accompanying delivery challan / test certificate.
- (f) Test Certificate/check list should accompany each supply. Consignments without test certificate, if asked for, are liable for rejection. Rejected material should be collected immediately (within 30 days) after our intimation by giving two days' prior notice for completing the necessary excise formalities. You should make arrangements to collect the material either personally OR through your authorized representatives. ITI does not take any responsibility to send the material back to you. After 90 days from the date of rejection intimation to you the material will be scrapped at your risk if not collected.

### 4. SAMPLES:

Those tenderers, who have not supplied the material against any of earlier orders, should submit FREE SAMPLES clearly indicating enquiry reference. Free samples along with your offer is preferable. In case of a Purchase Order on you, bulk supply should commence only after approval of samples and other approval formalities including infrastructure clearance.

### 5. WARRANTY: :( As per Enquiry: NSU5G51Y/II)

ITI Ltd., is an ISO accredited company. All our equipment systems have a warranty as per Enquiry No NSU5G51Y/ II from the date of dispatch to our customer. Hence, the warranty of your products should be as per Enquiry No NSU5G51Y/II from the date of supply if not specified explicitly. Within this warranty period, if any of your components/subsystem is found defective during our manufacturing process/system testing/installation & commissioning/operation of our equipment in the field, the same is to be replaced free of cost immediately by you. Warranty specified in the P.O. to be reckoned as final.

### 6. GENERAL:

- (a) We reserve the right to accept or reject any or all offers and to order full or part quantities or cancellation thereof without assigning any reason whatsoever.
- (b) Successful tenderer only will be intimated by post through letter of intent / firm orders.
- (c) Canvassing by tenderers in any form including un-solicited letters against tenders submitted or post-tender corrections shall render their tenders liable for summary rejection.
- (d) Any Plant/division of ITI reserves the right for placement of Repeat Order if required within one year of original date.

### 7. DELIVERY SCHEDULE:( As per Enquiry: NSU5G51Y/II)

- (a) Please indicate minimum lead-time required, manufacturing capacity and the quantity that can be reserved for us.
- (b) **Liquidated Damages Clause:** As per the tender document : ITI/NSU/BN3/WB-Z2/T&D Dated 06.05.2026

**8. LOCAL REPRESENTATION:**

Please indicate your local representative's address, telephone, Fax No., of the person to be contacted, in the offer.

**9. TECHNICAL CATALOGUE:**

The Technical Catalogue in English should be submitted. In the event of any change in the technical catalogue, updated version may be sent to us immediately. It is essential that you simultaneously take up the same with approval authority and their approval copy sent to us.

**10. GOVERNING LAW:**

All suits shall be instituted in a court of competent jurisdiction at Bangalore and in case of arbitration, the Indian Arbitration Conciliation Act, 1996 is applicable.

*Lendhy 06/05/26*  
Additional General Manager-MM(NS)



**NETWORK SYSTEM UNIT**  
(A Govt. of India Undertaking)  
Dooravaninagar. P.O. Bengaluru – 560 016  
Tel : 080 - 28503639, Fax: 080 –28503653  
[www.itilttd.in](http://www.itilttd.in)

[udhayanansvs\\_crp@itilttd.co.in](mailto:udhayanansvs_crp@itilttd.co.in)

[materials\\_nsu@itilttd.co.in](mailto:materials_nsu@itilttd.co.in)

**Tender Ref No: ITI/NSU/BN3/WB-Z2/T&D**

**Tender for “Selection of Partners for Aerial OFC and laying of OFC by the way of Trenching, Duct laying, Blowing/Pulling of OFC Cable in 02 districts of West Bengal for Bharat Net Ph-3 Network Project”**

**[Two Bid System (Technical Bid & Finance Bid)]**

## 1. INTRODUCTION

ITI Limited, a Public Sector Undertaking under the Department of Telecommunications, Ministry of Communications, is a leading Telecom equipment manufacturer and device provider in India. The major customers are BSNL, BBNL, MTNL, Defense, Paramilitary forces, Railways, Banks, Central & State Govt. departments, Institutions and research organizations. ITI has a pan India business footprint supported by the network of its Manufacturing units & MSP (Marketing, Services and Project) units at various locations.

ITI Limited has been undertaking various projects in all fields of telecommunications and information technology and also continuously deploying new technologies in the field of Telecom, ICT, Networking, e-Governance etc. ITI has diversified its operation and has been executing Turnkey projects in the field of Smart Infrastructure, Bharat net, and Defense Network Rollout etc.

## 2. GENERAL INFORMATION

**2.1 NAME OF WORK:** This Tender is being floated for “**Selection of Partners for Aerial OFC laying and laying of OFC by the way of Trenching, Duct laying, Blowing/Pulling of OFC Cable in 02 Districts of West Bengal for Bharat Net Ph-3 Network Project**”

SL NO	DESCRIPTION	INFORMATION
1.	REFERENCE NO. OF TENDER DOCUMENT	<b>Tender Ref No:</b> ITI/NSU/BN3/WB-Z2/T&D dated: 06.05.2026
2.	DATE OF UPLOADING OF TENDER DOCUMENT	06.05.2026
3.	MODE OF SUBMISSION OF TENDER	<a href="https://itilimited.ewizard.in">https://itilimited.ewizard.in</a>
4.	LAST DATE & TIME FOR SUBMISSION OF BIDS	16.05.2026 14.00 Hrs
5.	DATE & TIME OF OPENING OF TECHNICAL BIDS	16.05.2026 15.00 Hrs
6.	OPENING OF FINANCIAL BIDS	WILL BE INTIMATED LATER
7.	TENDER FEE	Rs. 11,800/- (Including GST)
8.	EARNEST MONEY DEPOSIT (EMD) IN EMD BG FORMAT .	Rs. 32 lakhs (Interest free EMD has to remain valid for a period of 45 days beyond the final bid validity period) Bidders registered as MSE (Micro & Small Enterprises) are exempted from submission of EMD. Such firms should produce proof of registration certificate in their own name from MSME department and NSIC & should provide Bid Security Declaration form as per ANNEXURE -III.

9.	THE AVERAGE ANNUAL FINANCIAL TURNOVER IN THE LAST 3 FY (FINANCIAL YEARS) i.e. (2022-23, 2023- 24, 2024-25)	Rs. 15 Cr
10.	ADDRESS FOR BID SUBMISSION	<a href="https://itilimited.ewizard.in">https://itilimited.ewizard.in</a>
11.	SECURITY DEPOSIT	5% of Tax invoice value retained from running bills
12.	VALIDITY	180 days from the last date of submission of bid.
13.	PERFORMANCE BANK GURANTEE	5% of WO cost/PO/LOI (incl. GST), valid throughout project period of 18 months + 60 days
14.	PROJECT COMPLETION	Within 12 months from the date of issue of first block-wise WO or else LD will be applicable.
15.	PRICE ESCALATION	NIL
16.	CONTACT PERSON	AGM MM - For queries. <a href="mailto:udhayanansv_crp@itiltd.co.in">udhayanansv_crp@itiltd.co.in</a> , <a href="mailto:materials_nsu@itiltd.co.in">materials_nsu@itiltd.co.in</a>
17.	SOLVENCY	Rs. 20 Cr
18.	PRE-BID MEETING	Pre bid meeting will be conducted at ITI Bhavan, Doorvaninagar, Bangalore- 560 016 or ITI Limited, Network System Unit, Doorvaninagar, Bangalore- 560 016 or through VC. Date and Time will be intimated.

### 3. TENDER INFORMATION

The tenders are invited in **TWO BIDS**, consisting of **Technical Bid and Financial BID (Price/Commercial)** as per **ANNEXURE-C**.

#### 3.1 TECHNICAL BID

3.1.1 Documents to be uploaded by the Bidder (Please upload supporting documents wherever required & applicable)

Sl. No.	Description	Compliance Documents to uploaded	Attachments	
			Yes	No
1.	Tender fee documents for submission/bidding of tender (If required as per tender fee)			
2.	Scope of work	As per <b>ANNEXURE-I</b>		
3.	Technical specification	As per <b>ANNEXURE-II</b>		
4.	Documents in support of submission of EMD for MSE registered with Undertaking for "Bid Security Declaration Form"	As per <b>ANNEXURE-III</b>		
5.	Company Profile			

6.	GST & PAN registration certificate			
7.	EPF registration certificate			
8.	All the pages of tender documents stamp signed/ digitally signed			
9.	Financial turnover for the last three years certified by the Chartered Accountant with registration number	As per <b>ANNEXURE-IV</b>		
10.	Work completion certificate/Experience during the last 7 (seven) years	As per <b>ANNEXURE-V</b>		
11.	Signed Pre-contract Integrity	As per <b>ANNEXURE-VI</b>		
12.	Mutual Non-disclosure agreement	<b>As per Annexure-VII</b>		
13.	Undertaking that the Bidder has not been Blacklisted/ Debarred	<b>As per Annexure-VIII</b>		
14.	Single point of contact (SPOC) details for official communication (Name, Mobile no., Email id, Address).	On company Letter head		
15.	Undertaking for “Declaration of Bidders”	<b>As per ANNEXURE-IX</b>		
16.	Copy of Power of Attorney of authorized signatory of the bid on stamp paper duly Notarized	<b>As per ANNEXURE-X</b>		
17.	EMD BANK GUARANTEE PROFORMA	<b>As per ANNEXURE-XI</b>		
18.	Self-declaration for not having any litigation History	<b>As per Annexure-XII</b>		
19.	PBG Bank Guarantee Performa	<b>As per Annexure-XIII</b>		
20.	Un-Priced Finance-Bid (Fill & upload separately)	<b>As per Annexure-XIV</b>		

### 3.2 ELIGIBILITY CRITERIA

S.No	Eligibility Criteria	Supporting Documents Required
A.	The Bidder should be registered under Indian Companies Act, 1956 or Limited Liability Partnership Act, 2008 or as amended; with at least 7 years of operations in India as on bid submission date.	Following documents in respect of sole Bidder shall be submitted: Copy of Certification of Incorporation /Memorandum of Association (MoA) and Articles of Association (AoA)/ registration certificate with LLP agreement

B.	<p><b>Turnover</b> The Bidder shall have minimum average annual financial turnover of Rs. 15 Cr in the last 3 FY (financial years) i.e. (2022-23, 2023- 24, 2024-25)</p>	Audited financial statements/annual report for 3 financial years i.e., (2022-23, 2023- 24, 2024-25) from the Statutory Auditor/ Chartered Accountant.
C.	<p><b>Net worth</b> The Bidder should have Positive Net Worth for the last 03 years i.e. (2022-23, 2023- 24, 2024-25)</p>	Audited Net worth certificate assigned by the company's Auditors/ CA for the last 03 years
D.	<p><b>Experience:</b> The bidder should have successfully carried out OFC laying work by using latest technologies of at least 500Kms of Underground or ADSS OFC cable in last seven years. <b>Note: Bidder shall have at least 60% experience in Underground OFC cable laying work.</b></p>	(i) PO & Work Completion Certificate issued & signed by the PO issuing authority or an authority authorized by the PO issuing authority of the client entity (central government departments/State Government departments/PSUs/Telecom Service Providers (Telco)/ Category-A ISPs) along with the supporting documents such as Work order/Purchase order OR Contract clearly highlighting the scope of work and quantities of the contract/ order.
E.	<p>The Bidder in the last seven years, must have successfully completed at least One OFC laying project (Underground or Overhead) with a value of Rs. 39 Cr or Two OFC laying project (Underground or Overhead) each with a value of Rs. 25 Cr or Three OFC laying project (Underground or Overhead) each with a value Rs. 20 Cr</p>	<p>Valid end customer PO copy during the last seven years with completion certificate.</p> <p>Note: 1. Multiple POs will be considered as a single work order against single contract or Agreement or project</p>
F.	<p>The Bidder should not be blacklisted/debarred with Ministry of Communication or BSNL/ITI or debarring order issued by Department of Expenditure (DOE), Ministry of Finance (MOF) covering all central Ministries/ Departments as per provision of OM No.F.1/20/2018-PPD by Department of Expenditure (DoE), MoF dated on 2<sup>nd</sup> Nov 2021 as on Bid submission date.</p>	<p>The Bidder shall submit: An undertaking signed by Authorized Signatory of the company to be provided on Non-judicial stamp paper of INR 100/- or such equivalent amount and document duly attested by notary public as per Annexure-VIII.</p>

G.	A self-certificate with proper contact detail of SPOC (Details of Contact person, Designation, Telephone Number, Fax, Official mail id etc.)	self-certificate with proper contact detail of SPOC to be provided
H.	The bidder should submit the solvency certificate from any one scheduled bank of India or from CA issued within 06 months prior to bid submission date	Rs. 20 Cr

### 3.3 GENERAL CONDITION

- a) After desktop planning, and approved initial route plans from ITI, the bidder shall conduct the physical survey for validation of the route and the ROW information.
- i. Desktop survey will be carried out by ITI.
  - ii. As per approved desktop plan, bidder shall carry the physical survey using the mobile App provided by ITI.
  - iii. Bidder shall submit the BoQ, finalized route plan as per the physical survey and get it approved from BSNL. ITI will facilitate the bidder in getting the approval from BSNL.
  - iv. ABD preparation shall be the responsibility of the bidder during the work executions.
- Refer Annexure - I for detailed scope of work for physical survey, submission of BoQ & route plan and ABD preparation and BharatNet Ph 3 tender vide ref. no. MM/BNO&M/BN-III/T-791/2024 dated 15.02.2024 and its amendments.
- b) Bidder shall start the physical survey immediately after the issuance of LOI. Bidder shall complete the physical survey as per the scope of work within One month from date of LOI.
- c) Preparation of applications for RoW permits from concerned agencies for laying of OFC and submit them to the agencies after approval from ITI and BSNL. ITI, along with BSNL, will extend necessary help in this regard. Any charges applicable for getting RoW permits shall be paid by the ITIL/BSNL on submission of Demand Note.
- d) Bidder should facilitate to obtain the demand note (ROW clearance) from respective authorities. The payment for ROW will be made by ITIL/BSNL based on Demand note directly to the concern authorities, if any for Bharat Net Ph-3 Project.
- e) The bidder shall start the OFC work immediately within 15 days from the date of clearance from the concern ITI authorities.
- f) Bidder would have necessary legal clearance for his work force like insurance, labor regulation license, EPF in the respective state etc.
- g) Establishment of at least one warehouse for storing the materials, like OFC, duct etc. The Bidder shall establish and maintain the warehouse(s) with security back up and insurance coverage for the temporary storage of materials required for OFC laying work. A proof for having set up the

warehouse(s) shall be submitted by the Bidder to ITI within 15 days of ITI's Work Order.

- h) Supply of major materials required for the OFC laying like, OFC (Both U/G and ADSS), HDPE duct, SJC/BJC and FTB/FDMS for fiber termination will be in the scope ITI.
- i) Supply and erection of the required GI poles of 7/8 Mtr (GI) including pole mounting accessories as per TEC GR and BIS standards, any other item required for completion of the project, will be in the scope of the bidder. The transportation of ITI supplied materials like OFC, DUCT, FDMS and SJC/BJC from central warehouse to workplace or bidder's temporary warehouse is the responsibility of bidder. For the material transit from central warehouse in WB to bidder warehouse/site/work location and warehouse at zone, insurance shall be the responsibility of the bidder.
- j) Arranging equipment's required for OFC laying and commissioning shall be the responsibility of the Bidder. This will include GI Poles, Jointing Chambers, Route Markers, Man Hole Marker, GI/DWC pipes, Pole mounting kits (for tension pole and support pole), OTDRs, and any other items required for completing the work and commissioning the network.
- k) End to end connectivity between nodes in GPs and Blocks are in the scope of the Bidder.
- l) Final testing and commissioning of OFC links will be done by ITI, however these activities will be supported by the bidder.
- m) **No Consortium allowed.**
- n) The bidder shall terminate the fibers at GPs and Block locations in the FDMS/FTBs.
- o) The bidder shall deploy multiple teams for execution of the OFC work at a time to meet the milestones mentioned in the tender.
- p) After handing over of materials from central warehouse, any losses due to theft or damage to the materials is in the bidder scope.
- q) The Bidder shall keep an accurate log book for receipt and utilization of materials at his/her warehouse(s) for the materials delivered to the Bidder. Receipt of materials shall be certified jointly by ITI Engineer as well as Bidder's authorized person for every receipt. ITI shall have the right to verify the material stock at any time.
- r) The Bidder shall be responsible for preparing the Bill of Quantities for the materials to be supplied by ITI as well as for the materials to be procured by the Bidder for project execution for his/her work, and the same shall be submitted to ITI within 15 days of ITI's Purchase Order.
- s) The successful bidder shall have WB GST registration and should establish office in West Bengal.
- t) Bidders who have executed/executing any projects (including BharatNet Ph 3 project) for ITI in the last 5 years, should produce satisfactory completion certificate issued not below the grade of AGM.
- u) **Bidders who won the Bid for two zones (1<sup>st</sup> and 3<sup>rd</sup>) of West Bengal pertaining to ITI tender ref.: NSU 5G 51Y dated: 24.07.2025 as well 2<sup>nd</sup> Zone NSU 5G 51 Y/I dt. 07.01.2026 are not eligible to**

**participate in this tender.**

- v) Bidder shall carry out the physical survey through ITI provided mobile App and prepare the required BoQ as per the survey. Bidder shall also coordinate with the ITI for updating the required details in the tools like GIS tool, Inventory tool etc as per the requirement. Bidder shall prepare the required ABD for the constructed OFC route.
- w) The tender will be evaluated based on the total value. Bidder shall submit signed unpriced bid attached at ANNEXURE-XIV along with the technical bid.

**3.4 FINANCIAL BID [PRICE/COMMERCIAL BID]**

The **Price/Commercial Bid**, consists of a document with the rate quoted in figures and words only in separate sealed Envelope/online uploaded quoted sheet as per **ANNEXURE-C**. Incomplete price bid is liable for rejection.

- i. Bidder /Firms who fulfill the requirements as mentioned in this tender document shall be eligible to apply.
- ii. Bidder can upload documents in the form of PDF format only.
- iii. Bidder must ensure to quote rate items separately as per format given in **Financial Bid** as per **ANNEXURE-C**.
- iv. If any cell is left blank and no rate is quoted by the bidder, Rate of such items shall be treated as rupees "0" (ZERO) or rejected for Bidding.
- v. The eligibility documents shall be opened first for technical bid on due date and time as mentioned above. Financial evaluation of Bidders/Firms who qualified in technical evaluation will be opened on the later date.
- vi. ITI Limited reserves the right to reject any or all the tenders without assigning any reason thereof.
- vii. The rates will be submitted as per the financial bid (**ANNEXURE-C**). Financial bid in another format shall be liable to be rejected. In case, if the bidders do not submit any tender relevant document as mentioned in Technical Bid, his bid will be outright rejected and bid will not be considered for further evaluation.
- viii. **GOVERNMENT LAW:** - All suits shall be instituted in a court of competent jurisdiction at Delhi and in case of arbitration; the Indian Arbitration Conciliation Act 1996 is applicable. Tender documents shall be filled, signed and submitted/Uploaded in original.
- ix. Any increase in taxes and other statutory duties/levies, after the expiry of the delivery date shall be to the supplier's account. However, benefit of any decrease in these taxes/duties shall be passed on to the Purchaser by the supplier. The total price is to be adjusted (by reducing the basic price) with increased duties and taxes as per price mentioned in PO/Tender.

Note:

- Tenders not submitted on time will not be considered and will be summarily rejected. Tender documents shall be filled and submitted all pages of tender signed/digitally signed [Submitted along with the technical bid].
- The conditional tender will not be considered and will be summarily rejected.
- There shall not be any financial quote in the Technical Bid, if it is added then said bid will be summarily rejected.

#### 4. EARNEST MONEY DEPOSIT (EMD)

As specified in the tender document EMD shall be payable with the bid. EMD is to be remain valid for a period of 45 days beyond the final bid validity period.

Bidders registered as MSE need not to submit the EMD. Such firms should produce proof of registration in own name with MSME and NSIC and should provide “**BID SECURITY DECLARATION FORM**” as **ANNEXURE-III**.

This shall be paid well in advance of tender submission time through Bank Guarantee in favor of ITI Ltd, N.S. Unit, Bangalore-560016. The Bank details is attached as ANNEXURE-XV. Proof/receipt of payment of cost of EMD to be uploaded.

##### **The EMD may be forfeited:**

- If a bidder withdraws the bid after bid opening during the period of validity.
- The information provided by the bidder is found to be false/forged document have been provided. This will entail black listing of the tender also.

**IN CASE L1 BACKS OUT:** In case The bidder withdraws during the technical evaluation and before financial bid opening, still the technical bid of such bidder will be evaluated and in case such bid in technically suitable and happens to be L-1, then also the tender must be discharged and EMD of the bidder will be forfeited.

**Return of Earnest Money deposit:** No interest shall be allowed on the Earnest Money deposit by the Bidder. The earnest money of the unsuccessful bidder will be refunded on their request after the finalization of the contract.

The Earnest Money deposited by the successful bidder will be adjusted towards the Security deposit for the fulfilment of the contract.

EMD shall be forfeited if the Bidder fails to submit the balance amount of Performance Bank Guarantee within 30 Days (i.e. 5% of the tendered value - the requisite security deposit). EMD of successful bidder shall be returned after submission of performance bank guarantee within 30 days.

## 5. PERFORMANCES CUM WARRANTY BOND:

- (i) PBG will be submitted by Bidder in the form of Performance Bank Guarantee (PBG) equal to 5% of the Purchase order value/Work order Value (incl. GST) through the scheduled bank of India in favor of ITI.
- (ii) PBG must be furnished within 15 days from the date of issue of LOI/WO and should remain valid for a period of 18 months plus 60 days.
- (iii) If the PBG validity is going to expire before completion of project, it will be obligatory on bidder part to extend the PBG validity period accordingly.
- (iv) If PBG is not submitted within 15 days from the date of issue of LOI, then the successful bidder may submit the same within 30 days with 12% penal interest on amount of performance guarantee from the 15th day to the date of submission within the cut off 60 days. However, if PBG is not submitted with 30 days, then ITI reserve the right to cancel the LOI duly forfeiting the EMD.
- (v) In case, PBG beyond 30 days is to be accepted under specific circumstances to with successful bidder, extension of maximum of 60 days with 12% annual interest will be given subject to approval from concerned authority of ITI.
- (vi) No interest shall be allowed on the PBG.

## 6. SECURITY DEPOSIT (SD):

In addition to PBG, Security Deposit 5% of tax invoice value will be retained as security deposit. In case the Bidder furnishes the Bank Guarantee from scheduled Bank against 5% SD, then the same may be accepted and EMD will be returned.

**Refund of Security Deposit:** SD will be returned after completion of project period and after deducting LD/loss to ITI due to negligence/delay on part of bidder and if following conditions are met.

- a) Final Payment of the Contract.
- b) Execution of Final Supplementary Agreement or Certification by Engineer that ITI has No Claim on Contractor.
- c) Maintenance Certificate issued, on expiry of the maintenance period wherever applicable.
- d) No interest shall be allowed on the Security Deposit.
- e) Finalization of material reconciliation.

## 7. PROJECT COMPLETION MILESTONE

During Development Period, the Bidder shall comply with the requirements set forth in this clause for each of the Project Milestones and the Scheduled Completion Date (the "Project Completion Schedule").

Based on the GIS data and route plan approved by BNSL/ITIL, the bidder has to construct and complete the OFC Network ring wise in the zone. Priority list of the rings will be provided along with the GIS data.

Initially work order will be issued for 70% of work, on satisfactory completion of the work, WO for remaining 30% will be issued.

Block wise work order will be issued separately, after route approval from BSNL.

The bidder to complete the awarded work **within 12 Months** from the date of issue of first block wise WO. T0 shall start from the date of issue of first block wise WO.

Supply of active & passive equipment required to be deployed at GPs and block HQ is in the scope of ITIL.

The Bidder shall complete the Project as per following Project Milestones (the "Project Milestones") during the Development Period:

**a. Project Milestone-I**

- i. Project Milestone-I shall be for 3 months from T0.
- ii. The Bidder shall have completed the Commissioning of OFC route **20%** of the total scope block wise.

**b. Project Milestone-II**

- i. Project Milestone-II shall be for 8 months from T0.
- ii. The Bidder shall have completed the Commissioning of cumulative OFC route of at least **70%** of total scope block wise.

**c. Project Milestone-III**

- i. Project Milestone-III shall be for 12 months from T0.
- ii. The Bidder shall have completed the Commissioning of cumulative OFC route of **100 %** of total scope block wise.

**Note:-**

- The work progress of the all bidders will be evaluated **every fortnightly** by ITIL and the performance will be rated based on the "%" of the completed work in the allotted work, GPs covered, rings completed in the zone and their acceptance by independent Engineer etc.
- If any bidder is found not performing in any zone, ITIL shall issue the warning letters for non-satisfactory performance. If the bidder is not improving even after receiving two such notices, ITIL reserve the right to terminate the contract and award the work to the other highest performing bidder at the risk and cost of the original bidder.

**8. LIQUIDITY DAMAGES (LD) CLAUSE:**

LD shall be as per the following clauses:

All the Gram Panchayats (GPs) should be connected as per the scope of work defined and Project Completion Schedule. The Penalties applicable for not meeting the Milestones are as below:

- a) Should the bidder fail to achieve the defined Project Milestone within the period, ITI shall be entitled to recover,
- b) At a sum equivalent to 1% of the value of the work order as per the delivery schedule of OFC work for each week of delay or part thereof for a period up to 10 (TEN) weeks.
- c) Thereafter, at the rate of 1.4% of the value of the work order as per the delivery schedule of OFC work for each week. (LD is capped at 24% of work order value).
- d) ITI reserves the right to terminate/cancel the work order for abnormal delay and complete the balance work at the risk and cost of the bidder. The timelines for completing the work shall be as defined in the P.O. released to the successful bidder and any delay shall trigger LD clause as mentioned above. Delay attributed to Force Majeure or enhancement in the scope of work by the way of modification or delay on the part of ITI in the clearing the site, furnishing of clarification, Supply of ITI materials etc. shall not attract LD.
- e) In addition to above clauses of LD, If the achievement of milestone is delayed due to the bidder, the applicable penalty LD shall be as per BSNL Bharat Net Ph 3 tender including amendments

**9. PAYMENT TERMS AND CONDITIONS:**

- a) Payment will be done block wise for as mentioned below.
- b) The Route length will be calculated based on the RODO meter readings, not the OTDR readings.
- c) Payment terms will be as given below:

Sl. No	Milestones	Payment
1.	80% of OFC laying work in the block	40% payment payable to the completed work
2.	90% of OFC laying work in the block	20% payment payable to the completed work
3.	100% of OFC laying work in the block with rings	20% payment payable to the completed work
4.	Lit up of 80% GPs with AT/Handover	5% payment payable to the completed work
5.	Lit up of 100% GP's with AT /Handover	5% payment payable to the completed

		work
6.	Completion of project	10% payment payable

### **OFC Maintenance till Handover**

After successful commissioning of OFC ring, the bidder shall maintain the OFC links till the handover to ITIL or ITI's associated partner with OTDR readings.

## **10. SPECIAL INSTRUCTIONS AND CONDITIONS**

### **10.1 Third Party Damage:**

If the bidder damages other Private Service provider's cables /sewage line/ Government or public properties, such as electricity cable or roads etc., the damage charges/penalty will be paid by the bidder only as per the claim of such third party. ITIL/BSNL/USOF, DoT will not be liable to pay any penalty or any damage charges made by the bidder as per the clause below:

- (i) "Successful bidder shall either pay to third parties all expenditure incurred for restoring services which are damaged by Successful bidder while carrying out the work or the same amount will be deducted from his bills. Such expenditure shall be intimated to Successful bidder either by Engineer in- charge or concerned third parties in writing."

### **10.2 UTILITIES**

#### **10.2.1 Existing utilities and roads**

Notwithstanding anything to the contrary contained herein, the bidder shall ensure that the Government Instrumentalities owning the existing roads, right of way or utilities, on, under or above the Site (Route) of the New Network and/or the Existing Network are enabled by it to keep such utilities in continuous satisfactory use, if necessary, by providing suitable temporary or permanent diversions with the authority of the controlling body of that road, right of way or utility, and shall initiate and undertake at its own cost, legal proceedings for acquisition of any right of way necessary for such diversion.

#### **10.2.2 Shifting of obstructing utilities**

During the execution of the underground OFC construction work, if there is a requirement of shifting of any utility including electric lines, water pipes and telephone cables etc, the bidder shall, first, explore an alternative path and execute the construction after getting approval of ITIL/BSNL BA Head. In case, no alternative path is feasible, the bidder shall explore the possibility of laying ADSS OFC for that section, and shall lay the same after getting approval from ITI/BSNL. In case where the shifting of utility becomes unavoidable, the bidder shall, subject to Applicable Laws, provisions of Applicable Permits and with the assistance of ITIL/BSNL, undertake shifting of any utility, including electric lines, water pipes and telephone cables, to an appropriate location or alignment within or outside the Site (Route) of the New Network and/or the Existing Network, if and only if such utility causes or shall cause a Material Adverse Effect on the development,

operation or maintenance of the Project. The bidder shall indemnify the Government Instrumentality for any damage to the utilities on account of the Development Works or the Upgradation Works.

### 10.3 Felling of trees

BSNL shall assist the bidder in obtaining the applicable permits for felling of trees to be identified by BSNL for this purpose if and only if such trees cause a material adverse effect on the development, operation or maintenance of the Project. In the event of any delay in felling thereof for reasons beyond the control of the bidder, it shall be excused for failure to perform any of its obligations hereunder if such failure is a direct consequence of delay in the felling of trees. For the avoidance of doubt, the costs and expense in respect of felling of trees shall be borne by USOF, DoT/ BSNL and any revenues thereof shall be kept with USOF, DoT/ BSNL.

### 10.4 Penalty for causing inconvenience to the Public

The bidder shall not be allowed to dump the empty cable drums/waste materials in Govt/public place, which may cause inconvenience to Govt/Public. If the bidder does not dispose off the empty cable drums/waste materials within 3 days of becoming empty, BSNL is at liberty to dispose off the drum in any manner deemed fit and the costs incurred by BSNL in disposing off such materials shall be borne by the Bidder. USOF, DoT/ BSNL/ITIL may also levy a **penalty up to Rs One Thousand for each such default.**

### 10.5 Penalty for cutting/damaging the old cable

During excavation of trench, utmost care is to be taken by the bidder, so that the existing underground cables of BSNL are not damaged or cut. In-case any damage/ cut is done to the existing cables of BSNL, a penalty as per the schedule given below will be charged from the bidder or the amount will be deducted from his running bills. Penalty shall be levied @20% of the penalty amount as per table below in case the repair of damages is carried out within 72 hours and submission of No Objection Certificate within 10 days of occurrence is received by the bidder.

Sl. No.	Size of existing UG/OF cables Cut/ Damaged	Amount of penalty per Damage instance
1.	Copper UG cable	Rs 50,000.00 (Fifty Thousand)
2.	OFC of any size	Rs 1,00,000 (one Lakh)
3.	Misc. (to include electrical cable, drainage/sewage pipe, water pipe belonging to state Govt or local municipal agency etc.)	Rs 1,00,000 (One Lakh)

The bidder shall carry out such repairs for restoration of the damaged cable free of charge. The cost of jointing kit shall also be borne by the bidder. If bidder fails to repair the damage, the cost of repair (including cost of labor + jointing kit) shall be recovered from the bidder in addition to the penalty as prescribed.

In accordance with Indian telegraph act, If any person, willfully or negligently damages telegraph line, he shall be liable to pay the expenses (if any), as may be incurred in making good such damage.

The bidder shall settle all such claim raised by other operators/ agencies regarding cutting/ damaging their cables or other infrastructure without any cost to USOF, DoT/ BSNL.

#### **10.6 Protection of Life and Property and Existing Facilities**

The bidder is fully responsible for taking all possible safety precaution during preparation for and actual performance of the works and for keeping the construction site in a reasonable safe condition. The bidder shall protect all life and property from damage or losses resulting from his construction operations and shall minimize the disturbance and inconvenience to the public.

If the excavation of trench alters the contours of the ground around road and highway crossing in such locations dangerous to traffic, the bidder shall at his own cost, take all necessary precautions to protect public and shall comply with all BSNL regulations as to placing of warning boards (minimum size 3' x 2'), traffic signals, barricades, flags etc., at such location. If the bidder does not put the warning signal as per above directions, then a penalty of Rs 1000/- per day shall be levied on the bidder, till the directions are complied by the bidder. The bidder shall take due precautions to avoid damages to other pipe lines, water mains, sewers, telephones, telegraphs and power conduits, laid wires poles and guy wires, railways, highways, bridges or other underground or above ground structure and/or property crossing or adjacent to the cable trench being excavated.

Attention of the bidder is drawn to the rules regarding laying of cables at road crossing, along Railways Bridges, highways safety precautions while working in Public Street as per Engineering Instructions.

The bidder shall be solely responsible for location through approved non-destructive means and ensuring the safety of all existing underground pipeline, electrical cables, and or other structures.

The bidder shall be solely liable for all expense for and in respect of repairs and/or damages occasioned by injury of or damage to such underground and above structures or other properties and undertake to indemnify USOF, DoT/ BSNL/ITIL from and against all actions, cause of actions, damages, claims and demands what-so-ever, either in law or in equity and all losses and damages and costs (inclusive between attorney and client), charges and expenses in connection therewith and/ or incidental thereto. The bidder shall take all responsibilities and risk in crossing other pipelines and cables and shall be responsible for protecting all such existing pipelines, poles, electric lines, sewers, cables or other facilities from damage by the bidder's operation in connection with the work. The bidder without cost of USOF, DoT/ BSNL/ITIL shall promptly repair any damage incurred.

The current market value of any commodities lost as a result of any damage to the aforesaid existing facilities shall be paid by the bidder together with such additional sums necessary to liquidate the personal of property damages, resulting there from.

#### **10.7 Labour Welfare Measures and Workman Compensation**

**Obtaining License before commencement of work.**

The bidder shall obtain a valid labour license under the Contract Labour (R &A) Act 1970 and the Contract Labour (Regulation and Abolition) Central Rules 1971, before commencement of the work, and continue to have a valid license until the completion of work. The bidder shall also abide by the provisions of the Child Labour (Prohibition and Regulation) Act 1986. Any failure to fulfill this requirement shall attract the penal provisions of the contract arising out of the resultant non-execution of work.

#### **10.7.1 Bidders Labour Regulations:**

The bidder shall ensure compliance of all statutory obligations, viz. payment of wages / salary to the workers engaged by him on regular and timely basis (by 7th every month) and any other amounts including any Statutory Dues, charges, taxes and levies payable as per the relevant statutes applicable and subsequent amendment thereof and same should be sole liability of Bidder and USOF, DoT/ BSNL/ITIL will not be liable in any circumstances whatsoever. The Bidder shall comply with the provisions of Employees State Insurance Act 1948, Workmen's Compensation Act, the Employees Provident Fund (and Family Pension Fund ) Act 1952, the Payment of Bonus Act 1963, the Industrial Disputes Act 1947, the Payment of Wages Act, Contract Labour (Regulation & Abolition) Act 1970 with Contract Labour (R&A) 1971 and / or any other rules, regulations and / or statutes that may be applicable from time to time or that may be introduced by the Central /State Government or Municipal / Local Self Government authorities, subsequent to the date of this agreement. Default on this account shall be deemed as sufficient ground for termination of the Agreement. In case of accident arising out of and in the course of this agreement. BSNL as Project Management Agency and USOF, DoT being owner/ Principal Employer will not be responsible for payment of any compensation or under any other law. It will be the sole responsibility of the bidder for payment towards loss or compensation whatsoever.

The person engaged by bidder shall be treated as bidder's own employees and they will claim no privileges from USOF, DoT/ BSNL/ITIL. The bidder will be directly responsible for administration of his employee as regards their wages, uniforms, general discipline and courteous behavior.

#### **10.7.2 Insurance:**

Without limiting any of his other obligations or liabilities, the bidder shall, at his own expense, take and keep comprehensive insurance including third party risk for machinery, men, materials etc. brought to the site and for all the work during the execution of T&D and Operation & Maintenance. The bidder shall also take out workmen's compensations insurance as required by law and undertake to indemnify and keep indemnified BSNL from and against all manner of claims and demands and losses and damages and cost (including between attorney and client) charges and expenses that may arise in regard the same or that USOF, DoT/ BSNL may suffer or incur with respect to end / or incidental to the same. The bidder shall have to furnish originals and/or attested copies as required by the department of the policies of insurance taken within 15 (fifteen) days of being called upon to do so together with all premium receipts and other papers related thereto which USOF, DoT/ BSNL may require.

#### **10.7.3 Compliance with Laws and Regulation:**

During the performance of the works the bidder shall at his own cost and initiative fully comply with all applicable laws of the land and with any and all applicable by-laws, rules, regulations and

orders and any other provisions having the force of law made or promulgated or deemed to be made or promulgated by the Government, Governmental agency or municipal board, Government of other regulatory or Authorized body or persons and shall provide all certificates of compliance therewith as may be required by such applicable law, By-laws, Rules, Regulations, orders and/or provisions. The bidder shall assume full responsibility for the payment of all contributions and pay roll taxes, as to its employees, servants or agents engaged in the performance of the work specified in the bidder documents. If the bidder shall require any assignee or sub-bidder to share any portion of the work to be performed hereunder may be assigned, sub-leased or sub-contracted to comply with the provisions of the clause and in this connection the bidder agrees as to undertake to save and hold USOF, DoT/ BSNL harmless and indemnified from and against any/all penalties, actions, suits, losses and damages, claims and demands and costs (inclusive between attorney and client ) charges and expenses whatsoever arising out or occasioned, indirectly or directly, by failure of the bidder or any assignee or sub-bidder to make full and proper compliance with the said by-laws, Rules, Regulations, Laws and Order and provisions as aforesaid.

**Note:**

***This RFP may be cancelled/withdrawn at any stage of the tendering process without any reason and prior intimation to bidders.***

## SCOPE OF WORK

### 1. SCOPE OF WORK

The bidder's scope of work covers the implementation of the middle-mile network for BharatNet program across the 02 districts of West Bengal. Tentative No of Gp's and Blocks in 2 districts of West Bengal are: No of Gp's - 227 and No of Blocks: - 21.

Construction: To build OF Cable network infrastructure across the 02 districts of West Bengal as per the approved survey of BSNL/ITI and terminate the all the fibers in the FDMS/FTB provided by ITIL.

End to end connectivity and Installation, testing and commissioning of OFC in GP's and block are in the scope of the Bidder.

Sl. No.	District	Approx. Total Fibre to be laid 1225Kms
1	Uttar Dinajpur	UG: 610
2	Cooch Behar	UG: 612

The above quantities are approximate/indicative and may vary during the execution phase. Payment will be made as per actual execution.

#### 1.1 DETAILED SCOPE OF WORK

##### 1.1.1 PHYSICAL SURVEY, SUBMISSION OF BoQ & ROUTE PLAN AND ABD PREPARATION

The total scope is 1225 Kms. Bidder shall deploy multiple teams simultaneously to carry out the physical survey activities and T&D activities to complete the scope of work within the project timelines. During the physical survey, bidders should capture and submit relevant details of GP & Block like infrastructure, solar panel, Power status, Earthing etc.

The delivery of ABD work will be completed along with trenching and ducting / Aerial work.

##### 1.1.2 GENERAL REQUIREMENTS

###### 1.1.2.1 GEOGRAPHICAL INFORMATION SYSTEM (GIS)

- Bidder shall perform GIS based physical survey using mobile App provided by ITI, detailed video graphic survey, GIS data collection during execution for creation of digital As Built Drawing (ABD).
- Bidder shall collect and maintain the inventory of both physical and logical resources of OSP (outside plant - fibre, chamber, splice-closure, coupler etc.), ISP (Inside Plant: room, rack equipment's and their connectivity) and power infra through Inventory tool.
- Bidder shall provide all required information related to network to S-NOC for fibre inventory management.

###### 1.1.2.2 ASSET MANAGEMENT

- Bidder shall manage the entire asset lifecycle of BharatNet infrastructure. Bidder in consultation with BSNL/ITIL shall assign unique identifiers or tags to network assets and infrastructure elements

in the field, such as fibre cables, splice points, junction boxes, and termination points etc.

### 1.1.3 FUNCTIONAL REQUIREMENTS FOR GIS MAPPING OF OFC ROUTES

- i. Accuracy: sub meter level accuracy (20cm).
- ii. Format: .shp format with mapping on Geography Coordinate System (GCS) projection system with WGS 84 datum.
- iii. Codification and layer structure will be provided by BSNL. The bidder shall be responsible to create separate layers for all network elements as per the requirement. However, the indicative structure of the shape files for Block, GP, route markers and OFC layers are as given below:

Block Layer (indicative)			
SN	Field	Type	Description
1	Name	String	Block Name
2	Asset Type	String	Block
3	Blk_Name	String	Block Name
4	Blk_Code	String	Block Code
5	Dt_Name	String	District Name
6	Dt_Code	String	District Code
7	St_Name	String	State Name
8	St_Code	String	State Code
9	Lat	Double	Latitude
10	Long	Double	Longitude
11	Cable_Len	Double	Cable Length
12	Remarks	String	if any
13	Obs	String	Observation
14	Status	String	Editing Status/It should be blank
15	Block_ip	String	IP address of BLOCK
16	geo_photo	String	Photo with geo-location
17	Vendor	String	Name of vendor
18	Phase	String	1/2/3
19	Model	String	DBOM
20	Technology	String	IP-MPLS

GP Layer (indicative)			
SN	Field	Type	Description
1.	Name	String	GP Name
2.	Asset Type	String	GP
3.	Asset_Code	String	GP Code
4.	LGD_Code	String	LGD Code for Location
5.	Location	String	Location Name of GP
6.	Loc_Type	String	School, College, GP, PANCHAYAT BHAWAN etc.
7.	GP_Code	String	GP Code
8.	NMSBLOCK_CD	String	NMS BLOCK Code
9.	NMSGP_C D	String	NMS GP Code

GP Layer (indicative)			
SN	Field	Type	Description
10.	Blk_Name	String	Block Name
11.	Blk_Code	String	Block Code
12.	Dt_Name	String	District Name
13.	Dt_Code	String	District Code
14.	St_Name	String	State Name
15.	St_Code	String	State Code
16.	Lat	Double	Latitude
17.	Long	Double	Longitude
18.	Cable_Len	Double	Cable Length
19.	Remarks	String	Remarks from BSNL
20.	Obs	String	Observations
21.	Status	String	Editing Status/It should be blank
22.	Block_ip	String	IP address of Block
23.	GP_mac_id	String	Mac Id of GP
24.	Otdr_len	Double	Length in meters
25.	Conn_str	String	PIC-PON- GP ID
26.	GP_sr_no	String	Device serial no.
27.	Backhaul	String	OFC or RF/Sat
28.	geo_photo	String	Photo with geo-location
29.	Phase	String	1/2/3
30.	Route_code	String	New/Old

OFC Layer (indicative)			
SN	Field	Type	Description
1	Name	String	OFC Route name
2	Asset Type	String	Leased/Incremental
3	Asset_Code	String	Segment Code
4	Blk_Code	String	Block Code
5	Dt_Code	String	District Code
6	St_Code	String	State Code
7	CS	String	Cable Section
8	Seg_Length	Double	Route length
9	Start_Node	String	Starting Asset
10	S_Cable_Len	Double	Starting Cable Length
11	End_Node	String	Ending Asset
12	E_cable_Len	Double	Ending Cable Length
13	num_fibre	String	24/48
14	Status	String	Editing Status/ It should be blank
15	Remarks	String	Remarks from BSNL
16	Obs	String	Observations
17	Traverse	String	FIBRE POSITION e.g. 'U' For Underground, 'O' for Overhead
18	fibre_pos	String	Left/ Right of the road
19	Direction	String	Towards GP or Block
20	Phase	String	1/2/3

OFC Layer (indicative)			
SN	Field	Type	Description
21	Route_code	String	New/Old

Route marker (indicative)			
SN	Field	Type	Description
1	Name	String	Route marker NAME
2	Type	String	Asset Type
4	Blk_Name	String	Block Name
5	Blk_Code	String	Block Code
6	Dt_Name	String	District Name
7	Dt_Code	String	District Code
8	St_Name	String	State Name
9	St_Code	String	State Code
10	Lat	Double	Latitude
11	Long	Double	Longitude
12	rd_Offset	Double	Offset from centre of the Road
13	CS	String	Cable Section
14	Remarks	String	Remarks from BSNL
15	Obs	String	Observations
16	cable_len	String	if any
17	Status	String	Editing Status/ It should be blank
18	geo_photo	String	Photo with geo-location
19	fibre_pos	String	Left/ Right of the road
20	Direction	String	Towards GP or Block
21	Phase	String	1/2/3
22	Route_code	String	New/Old

**Note:** For other required layers similar structure may be envisaged.

#### 1.1.3.1 GIS DATA COLLECTION

- i. Bidder shall conduct survey of the Block and associated routes from Block to Gram Panchayats (GPs) to evaluate the existing and new fiber cable needed for network implementation. Bidder shall do the physical survey and prepare the BoQ, and submit it for approval by ITI/BSNL.
- ii. Bidder shall collect coordinates of landmarks such as culverts, bridges / nallah, water bodies, crossroads, railway crossing, flyovers and public places like temples/mosques, bus-stop, PHC, post office, school/college, shops, police stations, banks, tourist spots, hospitals, etc. to be captured along with the route marker, cable joints, etc. along with the cable routes. One additional reading in the middle of the two manholes / RI should be recorded in the already laid network. Recordings are necessarily to be made at every fibre turn, bend along the route, road/railway crossing, culverts, diversion etc. Sufficient recordings at short intervals on the curvature of the route shall be captured to map it on GIS properly.
- iii. Bidder shall collect photos of various assets such as Blocks, GPs, manholes, joint chambers, FDMS, route markers etc. with geo tagged images.

- iv. Bidder shall collect information about terminated and spare fibres, loops, cable types/sizes and optical test results for each fibre, utilizing previously recorded data from BSNL. This includes port-by-port fibre configurations, termination details, and OTDR readings for Blocks and Gram Panchayats (GPs). Bidder shall collect cement/electronic route marker (lat-long) details for route marker identification.
- v. Bidder shall collect information about road length, width and type (RCC etc.), variation in width of road in meters taking offset from the center of the road.
- vi. Bidder shall gather details about authorities such as railway, National Highways (NH) and forest departments within the limits of the OFC path required for RoW permissions.
- vii. The point feature like poles, sewerage manholes, other utility chambers, transformers, bore well etc. shall be captured as a point.
- viii. The record of Block, GP and any utility shall be maintained within a 50-meter corridor with an accuracy of 20 cm (25 meters on each side of the road's center line or within the road's right-of-way, whichever is greater).
- ix. To and fro direction towards village, town, city etc. shall be recorded for all roads.
- x. The geo coordinates of all road KM stones shall be recorded and shown using symbol provided.
- xi. Note: All the asset locations on ground are to be geo-tagged in five photographs (one close-up and four from different directions covering road part and landmarks, if visible) and videography (zoom & wide angle) to be taken to identify the exact point later. There will be a practical situation where the route markers will be found missing, in such situation a play card with the notional assets no. available RID/ABD to be placed on the identified point.

#### **1.1.3.2 MOBILE APP FOR DATA COLLECTION FROM FIELD**

Bidder shall use ITI provided mobile application & video recording solution for the BharatNet Project to accurately document project activities such as trenching, fibre laying, splicing and equipment deployment. The key requirements are given below:

- i. Bidder shall record videos of depth, offset, chainage marking, etc. of overhead or underground alignment type of execution (HDD, OT, Aerial etc.)
- ii. The video should support to record and identify depth, offset, ofc accessories details and landmarks of routes.
- iii. Bidder shall ensure that the accuracy of videos and GIS coordinates is within the range of 20 cm. (a sample check of the survey shall be performed on the ground by IE to check the submeter level accuracy ( $\leq 20$  centimeters). BSNL/ITI may use CORS system deployed by Survey of India for measuring the accuracy during sample check. The survey data shall be rejected if the accuracy of the sample data is not in accordance with the desired accuracy).
- iv. The Bidder should use suitable devices such as GNSS / DGPS (which can be pole-mounted or

handheld as necessary), or any other appropriate technology and mobile applications for conducting surveys to capture GIS coordinates, videos, and photos of completed work.

- v. The ITI mobile app can be used as needed for capturing GIS coordinates, videos, and photos of executed work. The GNSS/ DGPS or any other device used by the Bidder must be compatible with the ITI mobile app. Bidder shall also upload videos in mp4 format and GIS coordinates in shape file format on BSNL provided GIS application.
- vi. All videos and photos shall be geo tagged and geo location shall be mentioned in file name. The geographical information shall also be available in header file.

### 1.1.3.3 VIDEO SPECIFICATIONS

- i. Format: MP4 format, minimum 720p & and above resolution, and 30 fps/60fps frame rate with HEVC codec for video compression.
- ii. Content: Each video segment shall clearly capture start and end points of activities, depth readings for trenching/drilling, manhole/cable chamber installation, details of OFC blowing/pulling, splicing activities, route markers, and active equipment deployment procedures.
- iii. Continuous recording: Videos shall be recorded continuously without cuts or edits, and file sizes should be optimized for efficient data exchange.
- iv. Visual evidence: Use calibrated vertical measuring tools to display depth in the video frame at every 10 meters for Open Trenching.
- v. Verbal commentary: Provide running commentary describing activities, depth measurements, and location references.
- vi. Date and time stamp: Automatically embed date and time stamps in recordings.
- vii. File naming: File names should clearly indicate the type of work, block, and route.
- viii. The following details (indicative) shall be captured in videos:
  - Chainage (CH) details
  - Methodology type
  - Depth and Offset details.
  - Lat long of each pit, RI, splice chamber landmarks etc.
  - Crossing of roads
  - 3 reference points of RI, Block and GP
  - Major crossing
  - Forest area, etc.

**Note:**

- Requirements for mobile device/ handset for ITI provided mobile app
- The Bidder shall have dedicated mobile for capturing implementation videos.

- Mobile device shall support minimum android version 13.0 & iOS version 15 for operating the mobile application.
- Mobile device shall support minimum camera capacity of 48 MP or higher and have at least 256 GB storage with augmented cloud storage capabilities as well.
- The camera should provide stable footage with minimal shaking or distortion.
- The video recording needs to be captured in sufficient day light and significant speed of maximum 40mtr/minute and minimum of 20mtr/minute.
- The video recorded and uploaded by Bidder shall also be stored by the bidder for future reference, extending for a duration of one year or until invoicing, whichever is higher.
- Mobile device shall support all the required features to fulfill the video recording requirements.

#### **1.1.3.4 GIS DATA UPLOAD AND VALIDATION**

- i. ITI shall provide App and measurement book format for uploading the captured data and information.
- ii. Bidder shall upload geotagged images and videos of designated locations in specified formats. The ITI mobile app shall be used to upload photos and videos to be taken from the sites.
- iii. To upload Block-wise data on GIS application mobile, BSNL/ITI will provide base maps to facilitate the upload and optimization of captured data and information, including fibre infrastructure and termination details etc.
- iv. Validation of uploaded data shall be done in two stages:
  - **First stage:** The bidder shall upload and verify the Block wise data/ videos/ photos in the GIS mobile application.
  - **Second stage:** Second level validation shall be done by IE of respective Block.
- v. If the data correction is required at any stage, the same shall be sent to the bidder for necessary correction.
- vi. Bidder shall be responsible to modify/ correct the data and submit for revalidation by the IE/ BSNL.

#### **1.1.3.5 DIGITAL AS-BUILT DRAWING (ABD)**

- i. As-Built Drawing (ABD) shall be created digitally on GIS platform.
- ii. Bidder shall record details of other operators and utilities such as underground optical fiber cables, utility pipes, transmission cables, and other similar infrastructure, in the digital ABD wherever possible.
- iii. The geo coordinates of all property boundaries within the fibre route corridor shall be recorded and shown in digital ABD.
- iv. Bidder shall capture physical OFC asset details and locations in respect of locations/ asset visited for capturing GIS data.
- v. Existing data as per documentations/ details made available to bidder w.r.t. to old OFC laid.

- vi. ABD shall be prepared from Block to GPs during implementation. The ABD for each block shall be prepared separately. ABD may have the following details:

<b>Particulars</b>	<b>Parameters to be captured (indicative)</b>
Cable details	<ul style="list-style-type: none"> <li>• Make and Size of the cable</li> </ul>
Joint details	<ul style="list-style-type: none"> <li>• Location of Joint Chamber (Lat/ Long details in decimal degree format up to six-digit precision)</li> <li>• Depth of Joint Chamber Cover from ground level</li> <li>• Details of cable stack at each joint chamber</li> <li>• 3 reference point of joint locations</li> </ul>
Route marker	<ul style="list-style-type: none"> <li>• Location of Route Marker Cement / Electronic (Lat/ Long details in decimal degree format up to six-digit precision)</li> <li>• Route Marker Identification details</li> <li>• 3 reference point of each route marker</li> </ul>
OFC Alignment Details	<ul style="list-style-type: none"> <li>• Offset of cable from centre of the road at every 10 meters (Details to be captured from HDD Graph / digital measurement book)</li> <li>• Details of crossings (road / rail / nala etc) should be provided.</li> <li>• Depth profile of cable at every 10 Meter (Details to be captured from HDD Graph / Measurement Book)</li> <li>• Details of protection with type of protection (Details to be captured from BSNL provided input)</li> <li>• Locations of culvert and bridges with their lengths and scheme of laying of HDPE / PLB pipe thereon</li> </ul>
Landmark Details	<ul style="list-style-type: none"> <li>• Important landmarks to facilitate locating the cable position in future to include important buildings such hospital, religious places, petrol pumps, educational institutes, government offices, commercial complex, major residential complex / building etc</li> </ul>
Road feature details	<ul style="list-style-type: none"> <li>• Electric Pole / Transformer</li> <li>• Telephone Pole</li> <li>• Utility Manhole</li> <li>• KM Milestone</li> <li>• Street Pole / Lamp Post</li> <li>• Median</li> <li>• Divider</li> <li>• Large Tree</li> </ul>

- vii. Readings shall be recorded without any exception at interval of 10 meters including every bend on the road, road/railway crossings, culverts, diversion etc. Each section shall record maximum 200 to 250 meter of the route length.
- viii. All the property boundaries within the corridor shall be recorded and shown in drawing. Three point's references need to be shown for every joint chamber/pull through chamber/manholes.
- ix. Collection of data shall also include custodianship of equipment in each Gram Panchayat.

- x. All the diagrams shall be verified by the Bidder (project manager level person) as a proof of accuracy of the details. The ABD may have the following details.
  - Name of the Project Organization
  - Name of the OFC Link with ID
  - Name of the PIA (ITIL)
  - Name of Survey Rep as part of acceptance test
  - Name of BSNL Rep (IE) as part of acceptance test
  - Date of commencement of work.
  - Date of completion of work
- xi. RoW: Railway authority, National highway, Forest authority and any other authority limit along with OFC path shall be captured in ABD (details will be provided in BSNL ancillary input data).
- xii. The Bidder shall also be provided an option to upload ABD in GIS format (.shp etc.) in the GIS platform through online tool to be provided by ITI. In such cases, bidder shall prepare ABD in GIS format (shape format) of OFC connectivity from Block location to respective Gram Panchayats (GPs), routes data shall be in soft copy.

#### **1.1.3.6 DIGITAL MEASUREMENT BOOK**

- i. Digital measurement book module of BharatNet C-NOC shall automatically calculate and update the work completed data including route length in RKM, depth etc. based on the videos uploaded during the execution of the work.
- ii. Bidder shall be responsible to provide/ update the measurement book information in the available PM tool MB module via mobile application to record work details in the C-NOC MB module if required. The recorded, reading in the MB cannot be deleted. The MB data shall be validated by the (approved/ rejected) by the IE. Bidder shall maintain and store all details of measurement book till the completion of C-NOC application. After completion of C-NOC, Bidder shall upload all required data in PM tool also.
- iii. Bidder shall also get an option for manual entry of records in digital measurement book of available PM tool in case of any issue faced in automated process.

#### **1.1.4 SURVEY AND PLANNING**

The tender mandates the Bidder to conduct an exhaustive video-based site and route survey based on an optimal/ shortest path to connect Gram Panchayat (GP) and Block. All the videos during Survey shall be taken using Mobile APP to be provided by ITI. Else, The Bidder shall take the videos as per the specifications, which shall be uploaded in the BharatNet GIS platform also in the CNOC. The bidder shall perform the following activities for site survey and planning:

- i. ITI shall provide the desktop survey details for site and route data of the Existing Network to the bidder on as is where is basis.
- ii. Bidder shall use such initial plan for physical site survey. Subsequently, Bidder must release final route plan after approval from BSNL for execution of work.

- iii. The bidder shall conduct an actual Geographic Information System (GIS)-based survey for the area under scope of work.
- iv. The Bidder shall record with videos, constraints about the changes in the desktop routes proposed based on physical survey. Independent Engineer (I.E.) and BSNL may use such evidences for approval of the design and BoQ. The access of such GIS based planning tool shall be given to the IE and BSNL/ITIL also.
- v. The Bidder shall ensure that the GIS based file formats should be compatible with BharatNet GIS platform. Furthermore, sharing and integration of GIS data under this project with the afore-mentioned platform shall be the responsibility of the bidder and BSNL/ITIL shall provide reasonable assistance in the same.
- vi. During the survey, the bidder shall consider connectivity till Gram Panchayat (GP) based on the optimal path for fibre layout covering maximum population en-route.
- vii. The bidder shall provide all the relevant drawings such as network diagram, L-14, As Build Diagram (ABD), related for the Development Works and/or the Upgradation Works for New Network and Existing Network to BSNL/ITIL and its designated agency. The network diagram shall include both High- and Low-Level Design (HLD & LLD).
- viii. The Bidder shall create/update the relevant engineering drawings/design in case of future upgradation, ensure updation of GIS platform and other relevant systems as required by BSNL/ITIL.
- ix. All engineering drawings/design and documents shall be created, updated and maintained by the bidder on its system/tool or portal and shall be accessible to BSNL/ITIL throughout the Contract Period. All these will eventually be handed over to BSNL and will become property of USOF, DoT.

#### **1.1.4.1 VIDEOGRAPHY**

- i. Videography for all the works like trenching, fibre laying, splicing etc shall be conducted by the bidder. The Video Recording (with Date/ Time stamping and GPS coordinates) of the OFC laying and Ducting works by the bidder shall be done in following phases as under:
- ii. Ducting - Video recording of Open Trenches is to be done using a Vertical Measuring Stick (Known as Measuring Staff in Civil Engineering Terms) at every 50 (Fifty) Mtr intervals. The depth reading in the Staff from top of the duct should be clearly recorded. In case of HDD (if the bidder is not using the machine recorded depth and produce the depth data), the depth of Entry & Exit pits should be Video recorded from top of the duct. The Couplers, Plugs and End Caps wherever required should also be captured in the video. Protection used in case of Low Depth should also be Video Recorded.
- iii. OFC Blowing/ Pulling - The OFC blowing process should be Photographed (geo tagged with time stamp) clearly showing the drum and fibre meter reading details.
- iv. Splicing- The splicing should be Photographed (geo tagged with time stamp) clearly showing that all 24F/48 F have been spliced and arranged in cassette.

- v. Man Hole/ Cable Chamber- The Cable Chamber of MH base should be Photographed ( geo tagged with time stamp) clearly showing the base plate of 50 mm thickness, RCC joint Chamber and Top Cover. The cable loop also to be video recorded – showing start and end readings.
- vi. Route Markers- Route Markers should be photographed (geo tagged with time stamp).
- vii. All Videos/ Photographs (geo tagged with time stamp) shall be submitted /uploaded with a unique location related name in a folder with file descriptions clearly indicating each of the above activities like Ducting, Blowing, Splicing, MH/CC & RM.
- viii. The MP4 Video should have 3 windows running concurrently for following views-
  - (a) Window 1 – Physical work being carried out with Lat/ Long and Date/Time stamp
  - (b) Window 2 – Location of the activity on Google Map.
  - (c) Window 3 – KMZ/KML file with chainage, OFC route, Depth, Offset from road centre & Lat/ Long of Joint pits etc.
- ix. Each Video file should be of at least 2 minutes time duration capturing works being done for 40 Mtrs in case of Open Trenching and one shot in case of HDD. The size of each Video file should not be more than 30MB so that the same can be sent through mobile/mail etc.
- x. The speed of movement of the camera while recording the Video should be maximum 20Mtr/Minute.
- xi. All Video recordings should be done in day light time without rain, fog, mist etc. Wherever, the video recording is not possible, photographs should be taken at every 10 meters with the approval of BSNL.
- xii. The nomenclature of the files should be in the following format:- XXXX\_YYYY: 12345\_67890: Work  
XXXX is the Route Abbreviation as per the Work Order  
YYYYY is the Circle+District+Block Abbreviation as per the Work Order 12345 is the Chainage of start point of Video Recording  
67890 is Chainage of end point of Video Recording  
Work- OT Ducting- OTD, HDD, OFC Blowing- OFB, Splicing- OFC, MM/CC, RM etc.
- xiii. Block end should be Chainage '0' and GP end should be taken as the last Chainage.
- xiv. The Backend team of the bidder should merge all the files of a section of 40 meters in succession or HDD shot and send to ITI/BharatNet BA team of the Circle for review / verification of works and GIS NOC for linking the same with GIS.

Note: GPS enabled Camera/mobile phone, that can record Video with live tracking of LAT LONG (GPS Coordinates) and Date/ Time Stamping shall be used by the bidder. Video output resolution should not be less than 720dpi.

RKM is the Route Kilometers measured along the route length only.

For further clarifications refer BharatNet Ph 3 tender vide ref. no. MM/BNO&M/BN-III/T-791/2024 dated 15.02.2024 and its amendments.

### **1.1.5 CONSTRUCTION OF THE OFC NETWORK**

Ring architecture: Bidder shall be responsible for implementing the Optical Fiber Cable (OFC) network (Underground and Aerial). The bidder shall conduct the physical survey of routes using the mobile app provided by ITI. Bidder shall submit the BoQ, finalized route plan and get it approved from BSNL. ITI will facilitate the bidder in getting the approval from BSNL. Primarily, bidder shall plan OFC construction through underground laying. However, wherever, the same is not possible, the next alternative shall be ADSS OFC laying preferably using existing electricity infrastructure. The same shall be approved by ITIL/BSNL based on recommendation of IE with appropriate justification and constraints for underground laying.

The bidder shall be responsible for connectivity across all Gram Panchayat (GP) as per the approved survey reports provided by ITIL.

Based on the network infrastructure to be deployed under this project, all permissions shall be obtained by the bidder, as required under Applicable Laws, relevant Applicable Permits, license(s), authorization (s) and permissions from Department of Telecom / Government of India/ State Governments.

### **1.1.6 OFC IMPLEMENTATION**

The Bidder shall follow an optimal mix of underground and aerial optical fibre cable based on terrain types across the State of West Bengal. The implementation through aerial optical fibre cable shall only be resorted where implementation through underground OFC laying is not feasible either due to terrain or ROW approvals.

#### **a. OFC network construction**

24/48 core fibre are to be deployed to connect all Gram Panchayats (GPs). Based on the approved site survey report and network design, the bidder shall be required to initiate OFC implementation and comply with specifications and standards.

#### **b. Establishment of at least one warehouse in each Zone for storing the materials, like OFC, duct etc.**

The Bidder shall establish and maintain the warehouse(s) with security back up and insurance coverage for the temporary storage of materials required for OFC laying work. A proof for having set up the warehouse(s) shall be submitted by the Bidder to ITI within 15 days of ITI's Work Order.

#### **c. Supply of major materials required for the OFC laying like, OFC (Both U/G and ADSS), HDPE duct,**

SJC/BJC and FTB/FDMS will be in the scope ITI.

- d. Any damage or theft of materials after collecting of material from ITIL, it is responsibility of the bidder to replace the theft/damage items on his own cost.
- e. The bidder should maintain the inventory logbook of material received from ITIL, utilization and balance materials. ITIL may do the inspection at any time.
- f. The bidder should inform ITIL, in writing, about the material requirement in advance depending up on the available balance quantity. So that ITIL may arrange the material in advance.
- g. The bidder shall perform all activities required for end-to-end implementation of under-ground and aerial OFC, within the stipulated time.
- h. For the routes, where ADSS is approved as implementation design, the bidder may leverage existing power distribution poles for stringing, jointing, live line installation and commissioning of optical fibre cable from the nearest Block to Gram Panchayat (GP) using appropriate pole clamping and accessories.
- i. The bidder shall perform end-to-end testing of the OFC laid till Gram Panchayat (GP) in accordance with good industry practice, specifications and standards, and acceptance testing template for quality assurance.
- j. Preparation of applications for RoW permits from concerned agencies for laying of OFC and submit them to the agencies after approval from ITI and BSNL. ITI, along with BSNL, will extend necessary help in this regard. Any charges applicable for getting RoW permits shall be paid by the ITIL.
- k. Bidder should facilitate to obtain the demand note (ROW clearance) from respective authorities. The payment for ROW will be made by ITIL based on Demand note directly to the concern authorities.

#### 1.1.7 MEASUREMENT

- i. **Measurement Book:** The measurement books are to be maintained by the Bidder. The Entry shall be made in ink. No entry shall be erased. If a mistake is made, it should be corrected by crossing out the incorrect words or figures and inserting the corrections, the corrections thus made shall be initialed & dated by the bidder. The measurement books shall invariably be consulted at the time of making final payments to the bidder.
- ii. **Method of recording of nomenclature of items:** Complete nomenclature of items need not be reproduced in the measurement book for recording the measurement but corresponding item code as provided, shall be used.
- iii. The measurements of various items of work shall be taken and recorded in the measurements book.

The measurements shall be taken and recorded by bidder which will be countersigned by the authority appointed by ITI/BSNL and/or IE. The bidder shall be directly responsible for supervision of work and for accuracy of 100% of measurements. The IE will be responsible for conducting Acceptance Test (A/T) check of measurements at different locations on sample basis. The bidder shall re-do the work, wherever, the IE finds deviation from the entries in MB by the ITI or BSNL at any subsequent stage during contract period. During subsequent inspection by BSNL or any other agency, in case the sample measured data does not match with the measurement book entry up to a lesser depth of 5cm, penalty (equal to amount of difference of payment, so reduced due to lesser depth ) shall be levied in addition to the reduction of payment due to lesser depth as per the approved formulae on each such default instance on the payment due for the link (waiver of penalty, if warranted, shall be decided by on case to case basis) . The spirit is to ensure correct recording in the measurement book by the bidder. ITI, reserve the right to get the work done at the risk and cost of the bidder in case of lesser depth cases.

**iv. Method of measurement:** The measurement of the work shall be done activity-wise as and when the item of work is ready for measurement. The methods of measurement of various items are enumerated as under:

a. **Measurement of Depth of Trenches:** The cable route shall be divided into number of segments each of maximum 200 Meters length bounded by identifiable landmarks at both the ends of the segments. If landmarks are not available, length of segment may be maintained at 200 Meters. The measurement of depth shall be recorded at each point of measurement (POM) in the measurement book in Meters in the multiples of 5 cms.

For example, 97 cms will be recorded as 95 cms and 103 cms as 105 cms.

The points of measurements shall be at a distance of 10 Meters starting from 0 (Zero) Meter. For example, if the length of segment is 75 Meters, the POMs shall be at 0 M, 10 M, 20 M, 30 M, 40 M, 50 M, 60 M, and 70 M. The last POM shall be at 75th M to be recorded against residual POM. Normally the workers tend to dig shallow trenches due to effort involved. As standard depth of the trench is important for future life and protection of cables, this tendency must be discouraged.

b. **Measurement of lengths and profiles of strata and protection:** The measurements of length of trenches are on running Meter basis, irrespective of type of soil encountered while digging. The type of protection utilized (item code – wise) to include RCC Half Round and Full Round Pipe, DWC HDPE Pipe, GI Pipe, MS Weld Mesh etc in a segment shall be recorded in the measurement book in the sheet provided for this purpose.

c. **Measurement of length of cable:** The length of cables laid in trenches, through pipes and through ducts shall be measured by using OTDR for the purpose of accuracy of the identification of cuts during O&M. **The payment for such laying/trenching as per price schedule shall be made as per the RODO Meter readings and not as per the OTDR readings.** The length should be cross-

verified with the marking of lengths on the cables. The lengths shall be recorded in sheet provided in the measurement book.

**v. Measurement of other items:**

- i. The measurement/ numerical details of other items shall be recorded in the sheets provided for respective items viz.
- ii. Digging of joint pit/manholes and preparation of chambers along with details of its dimensions and location.
- iii. Fixing, Painting and sign writing of route/joint indicators.
- iv. Termination of Cable in equipment room and no. of joints.
- v. Record splice loss details for each joint.
- vi. The bidder shall sign all the measurements recorded in the measurement book. This will be considered as an acceptance by the bidder, of measurements recorded in the MB. In case bidder fails to attend at the measurements or fails to countersign or to record the difference within a week, then in any such events the measurements taken by IE shall be final and binding on the bidder and the bidder shall have no right to dispute the same. In case of any difference of opinion in the measurement book between IE and the bidder/ITI, same shall be mutually discussed and agreed before making it final.
- vii. Measurement of the work of cable for calculation of laying /trenching will be taken equal to the length of the pipe/ duct (as measured in the RODO meter) through which the cable has been pulled and not the total length of the cable pulled through pipe/duct.

**vi. Uploading of Depth Photographs:**

- i. The ITIL/IE responsible for verification of MB shall take the photographs of the depth measurement being done at every 100 m in case of open trench work and at the entry / exit points in case of HDD method using Bharat Net GIS App and upload the same on GIS platform.
- ii. Compilation of the Measurement Book needs to be on real time basis while the work is being carried out.
- iii. The details noted by the Contractor in the notebooks will be entered in the proper MB format in the computer on weekly basis and will be shared with ITIL. These shall be checked by IE(BSNL) progressively so that as soon as the work of the route is complete, the MB is also ready.
- iv. Depth AT and other tests/ observations to be done while the work is being executed.
- v. The bidder should ensure proper recording of all the details like drum Nos, duct roll numbers and length of shots etc.

**1.1.8 RATES PAYABLE IN CASE OF LAYING AT LESS DEPTH**

- i. The nominal depth of OFC laying in plain area/ soft soil is 165 cm and that in the hilly area is 120 cm.
- ii. The minimum depth allowed in plain area/soft soil will be 100 cm and that in the hilly area will be 30 cm.
- iii. Depth below 100 cm in plain/soft soil and 30 cm in hilly area will be allowed under exceptional

circumstances with the approval of ITIL/CGM (BSNL) concerned.

iv. The payment, in case of less depth, shall be done as under:

**a. In Plain Area**

Sl. No.	Depth (with relaxation)	Protection as per EI	Cost of protection (Rs per mtr)	Payment without protection (%)
1	165- 150 cm	No Protection	--	150*97/165
2	150- 120 cm	No Protection	--	120*93/165
3	120- 100 cm	DWC	65	100*85/165
4	100- 60 cm	GI*	550	60*76/165
		CC*#	6000 per Cubic M	
5	60- 30 cm	RCC#	8000 per Cubic M	30*76/165

\* Any one protection can be used # rates are in per Cu Mtr

**b. In Hilly Area**

Sl No.	Depth (with relaxation)	Protection as per EI	Cost of protection (Rs per mtr)	Payment without protection (%)
1	120- 100 cm	No Protection	--	100*97/120
2	100- 80 cm	No Protection	--	80*93/120
3	80- 50 cm	DWC	65	50*85/120
4	50-30 cm	GI*	550	30*76/120
		CC*#	6000 per Cubic M	
5	< 30 cm	RCC#	8000 per Cu M	20*76/120

\* Any one protection can be used # rates are in per Cu Mtr

- v. In case of depth between 100 Cm to 60 Cm in plain terrain and 80 cm to 50 cm in hilly terrain, the protection of G.I. pipe or CC (1:2:4) shall be done for 25 cm\*25 cm encasing the PLB.
- vi. In case of depth is 60 cm to 30 cm in plain terrain and 50 cm to 30 cm in hilly area protection of RCC (1:2:4) shall be done for 25 cm\*25 cm with 12 SWG G.I. mesh of 50 mm\*100 mm size.
- vii. The DWC, CC and RCC protection will be retained in EI the rest protection like RCC pipes will be removed from EI.

### 1.1.9 INSPECTION AND ACCEPTANCE TESTING

During the Project execution, ITI/BSNL shall have the right to inspect, test and audit the network infrastructure and modalities across processes to construct, operate and maintain the network till Gram Panchayat (GP) during construction and operation period i.e. throughout the lifecycle of the project.

For determining that the Development Works and/or the Upgradation Works conform to the Agreement, the IE shall require the bidder/ITI to carry out or cause to be carried out tests, at such time and frequency and in such manner as may be specified by the IE from time to time in accordance with Good Industry Practice, Specifications and Standards, and Acceptance Testing Template for

quality assurance.

The bidder shall perform and facilitate the following with regards to testing activities:

**a. Supply of products/ material or network infrastructure**

In case the product / material supplied for the Project does not conform to the Specifications and Standards or is deficient in terms of relevant certificates / documents / test results, as inspected by ITIL/BSNL or IE, then the costs to be incurred on any replacement of such product / material shall be borne solely by the bidder.

**b. Deployment of products/material or network infrastructure**

- i. The acceptance testing (A/T) of the OFC Network shall be carried out as per the Acceptance Testing Schedule issued by QA and Inspection Circle of BSNL which can be accessed on line from the website of QA and Inspection Circle of BSNL. As validated by the IE, such tests along with Acceptance Testing Template shall be designed in conformance with the provisions set forth under Annexure-II (Technical Specifications), Specifications and Standards and Good Industry Practice.
- ii. The bidder shall, no later than 30 (thirty) days prior to the likely completion of the construction, notify the IE and ITI/BSNL of its intent to subject the infrastructure to tests.
- iii. Further, no later than 10 (ten) days prior to the actual date of tests, the bidder shall furnish detailed inventory and particulars of all works and equipment forming part of the Project to the IE and BSNL.
- iv. In the event of the bidder/ITI and the IE failing to mutually agree on the dates for conducting the tests, the bidder/ITI shall fix the dates by not less than 10 (ten) working days' notice to the IE, and in the event the IE delays the tests hereunder, BSNL shall ensure that tests are completed in time either by the IE or any substitute thereof.
- v. The bidder shall progressively self-conduct and perform Preliminary Acceptance Testing (PAT) for network infrastructure being created as per the scope of work.
- vi. All tests shall be conducted in accordance with Acceptance Testing Template duly approved by BSNL at the cost and expense of the bidder. The IE shall undertake the tests only when all the Gram Panchayat (GP) offered for testing are visible in the NOC.
- vii. Once the Bidder performs the PAT, it shall offer network infrastructure within a Block subject to minimum 10% Gram Panchayat (GP) completed and pinged from the Central NOC or visible in SNOC, for testing purposes to the IE for Final Acceptance Test (FAT). Inspection work for FAT within a Block shall be offered only after completion of PAT of the route and site location by the bidder.
- viii. The schedule for such testing shall be based on a project plan and the timelines for the same shall be agreed between IE and bidder/ITI. In case of any changes in the schedule or plan, bidder shall notify the IE and ITI, 10 (ten) working days prior to the scheduled date.

- ix. In pursuance of the provisions of this Agreement, the IE shall conduct visual and physical check of the infrastructure at Blocks and Gram Panchayat (GP) and central locations (i.e. NOC) to determine that all works, equipment, and services forming part thereof conform to the provision of this Agreement and the detailed scope of work.
- x. The IE shall perform tests of offered Gram Panchayat (GP) aggregated at Block level in accordance with Good Industry Practice, Specifications and Standards, and Acceptance Testing Template. Sample sites and its routes to be checked shall be decided by the IE.
- xi. The bidder shall facilitate the IE in conducting the tests as per approved Acceptance Testing Template and/or as per directions of the IE. All reasonable facilities and assistance like testing instruments and other test devices including access to drawings and other details shall be furnished, by the bidder to the ITIL/IE and BSNL.
- xii. The cost of all associated works regarding testing as per the scope of work such as digging pits at sample sites for connectivity across Gram Panchayat (GP), its restoration, and arrangement of testing instruments such as OTDR etc. shall be borne by the bidder.
- xiii. The IE may also decide to witness, or participate in, any of the tests to be undertaken by the bidder for its own quality assurance in accordance with Good Industry Practice, Specification and Standards, and in such an event, the bidder shall cooperate with, and provide the necessary assistance to, the IE for discharging its functions hereunder.
- xiv. Result of IE's inspection and audit shall only be valid for Gram Panchayat (GP) which were offered for testing under a Block. If bidder offers a Block for inspection more than once, IE and BSNL reserve the right to include or exclude the test of previously completed Gram Panchayat (GP) as well.
- xv. The overall result(s) of the FAT conducted by IE/ BSNL shall be indicated as "Satisfactory" or "Unsatisfactory" as judged at the time of inspection on merits of each case. The results of the test shall be jointly signed by the authorized personnel of the bidder, ITI and IE.

In case of classifying the work as "Unsatisfactory," the bidder shall highlight the reason for non-compliance as per the Specifications and Standards set forth under Annexure-II and Good Industry Practice along with design requirements under the scope of work of the tender. The results of the FAT conducted shall include submission of all relevant documents such as measurement book, Acceptance Testing Template report etc.

Further, "Unsatisfactory" cases shall be communicated to the bidder by the ITI for its rectification.

- xvi. During a FAT, if more than 10% discrepancies across site route or locations across Gram Panchayats (GPs) are observed within a Block which may be attributed due to negligence on the part of the bidder, under such circumstances, the FAT may be rejected.

Further, the Bidder shall get the work redone in a time bound manner and re-submit FAT report

compliance, upon which ITI/IE/BSNL shall have to recheck the offered Gram Panchayat (GP) and may also extend the sample size of site route or locations across Gram Panchayats (GPs) for discrepancies and record its observations. However, if the discrepancies are less than 10% within a Block, then ITI/ IE/ BSNL shall provide a provisional acceptance and issue a Provisional Acceptance Certificate as per provision set forth in this Section.

However, the issuance of Provisional Acceptance Certificate shall be subjected to the visibility of Gram Panchayat (GP) in the Network Operations Centre (NOC). In such an event, the Provisional Acceptance Certificate shall have appended thereto a list of outstanding items signed jointly by the Independent Engineer and the bidder (the "Punch List"); provided that the Independent Engineer or BSNL shall not withhold the Provisional Acceptance Certificate for reason of any work remaining incomplete if the delay in completion thereof is attributable to BSNL.

**c. Rectification of defects and deficiencies**

- i. The bidder is obligated to rectify the outstanding item or Punch List in a time bound manner to receive a Final Acceptance Certificate on the same as per provision set forth under Annexure-I clause 1.1.5.b.xvi of this tender. In this process, the bidder shall comply with the timelines of the construction milestone and shall be responsible for delays on the re-work on its scope.
- ii. In case any inspected or tested components/site route fail to conform to the Specifications and Standards and design requirements as per provisions set forth in Annexure-II, the bidder shall either replace the rejected components or make all alterations necessary to meet specification/requirements, without any additional cost to ITI/BSNL.
- iii. If any equipment or any part thereof is found to be defective or fails to fulfil the requirements as per provisions set forth in Annexure-II, ITI/BSNL shall give notice to the bidder setting forth details of such defects or failure and the bidder shall at their own cost make the defective equipment good or alter the same to make it comply with the requirements forthwith, within a period not exceeding one month of the initial report. These replacements shall be made by the bidder free of all charges at site and route locations.
- iv. Further, in the entire process the ITI/IE/ BSNL shall make a report of inspections (the "**Inspection Report**") performed as a part of FAT. The Inspection Report shall state defects or deficiencies, if any, with reasonable details and reference to the Specifications and Standards and design requirements as per provisions set forth in Annexure-II. IE shall send a copy of the Inspection Report to BSNL and the bidder within 7 (seven) days of such inspection and upon receipt thereof, the bidder shall rectify and remedy the defects or deficiencies, if any, stated in the Inspection Report. Notwithstanding the foregoing, such inspection or submission of Inspection Report by the IE shall not relieve or absolve the bidder of its obligations and liabilities hereunder in any manner whatsoever.
- v. Based on the Inspection Report or the defect and deficiencies observed in the Project, the IE/ BSNL

shall verify whether remedial measures have brought the Development Works and/or the Upgradation Works into compliance with Specifications and Standards and design requirements as per provisions set forth in Annexure-II.

- vi. The procedure for closure of defect and deficiencies as reported shall be repeated until such Development Works and/or the Upgradation Works conform to the Specifications and Standards and design requirements as per provisions set forth in Annexure-II. Further, it is agreed that the tests pursuant to this shall also be undertaken in addition to and independent of the tests carried out by the bidder for its own quality assurance in accordance with Applicable Laws, Applicable Permits and Good Industry Practice. It is also agreed that a copy of the results of such tests shall be sent by the bidder to the ITI and IE forthwith. The costs to be incurred on any test which is undertaken for determining the rectification of any defect or deficiency in the Development Works and/or the Upgradation Works shall be borne solely by the bidder.
- vii. Upon successful completion of tests, the IE/ BSNL shall issue the Completion Certificate, as the case may be, in accordance with the as per provision set forth under Annexure-1 clause 1.1.5.b.xvi of this tender.

If the IE/ BSNL certifies to BSNL and the bidder that it is unable to issue the Completion Certificate or Provisional Acceptance Certificate, as the case may be, because of events or circumstances on account of which the tests could not be held or had to be suspended, the bidder shall be entitled to re-schedule the tests and hold the same as soon as reasonably practicable.

#### **1.1.10 Service Level Agreement hereinafter referred as SLA and penalties**

##### **1.1.10.1 Construction Phase**

- i. All the Gram Panchayats (GPs) should be connected as per the scope of work defined and Project Completion Schedule. The Penalties applicable for not meeting the Milestones are as below:
- ii. Should the Bidder fail to achieve the defined Project Milestone within the period, without prejudice to other remedies available to it shall be entitled to recover, as agreed, liquidated damages (LD) as follows.
  - a. At a sum equivalent to 0.5% of the value of incomplete GPs as per milestone for each week of delay or part thereof for a period up to 10 (TEN) weeks, and thereafter
  - b. At the rate of 0.7% of the value of the incomplete GPs as per milestone for each week of delay or part thereof for another 10 (TEN) weeks of delay. (LD is capped at 24% of work order value).
  - c. The Value of incomplete GP for the purpose of calculation of LD shall be taken as equal to the Total Project Cost (PO Value) divided by the number of GPs
- iii. Non-completion of the targets of any Project Milestone even at the occurrence of the next

Project Milestone shall render the bidder liable to any or all of the following sanctions:

- a. Forfeiture of its performance security,
- b. Imposition of penalty, and/ or
- c. Short- closure of the contract in part or full and/ or termination of the contract for default.

### **1.1.11 Quality Assurance and Testing**

#### **1.1.11.1 Indigenous Equipment**

- i. The supply of all materials shall be accepted only after Quality Assurance tests, carried out by the QA circle. For other items which do not have TEC GR, QA shall be done based on a test schedule submitted by the Successful Bidder and approved by ITI/BSNL. The relaxation of QA requirement, if necessary, shall be given by ITI/BSNL on a case-to-case basis.

In case of failure of any component during the Bulk QA testing-

1. Complete lot shall be deemed as rejected. The same lot shall be offered again for Bulk QA testing by the concerned OEM.
2. The offered quantity shall be equal to that of the rejected lot. For such re-offered lot (post rejection), Bulk QA testing shall be done on the 100% offered quantity.
3. For all the further offered lots (post rejected lot), Bulk QA testing shall be done on the 10% more quantity than the prescribed quantity as in sub-clause-(i) above (i.e. 20%, 10% or 5%, as the case may be).
4. As mentioned at para- (1) & (2) above, for all the re-offered lot (post rejection), Bulk QA testing shall be done on 100% offered quantity.
5. After each rejected lot, Bulk QA testing shall be done on 10% more quantity than the previous successfully tested lot, as mentioned at para- (3) above.  
*{see illustration-2 below}*

The bidder/ respective OEM shall make the suitable arrangements for such Bulk QA testing.

**Illustration:** *An OEM qualify (as per actual experience and required supply) for 20% Bulk QA testing and equipment is to be offered in 10 lots. If the 3<sup>rd</sup> lot is rejected, the same lot shall be re-offered and 100% quantity shall be tested for Bulk QA. For 4<sup>th</sup> lot onwards, Bulk QA testing shall be carried out on 30% of offered quantity. Further, if 7<sup>th</sup> lot is rejected, 100% quantity of re-offered 7<sup>th</sup> lot shall be tested. For 8<sup>th</sup> lot onwards, Bulk QA testing shall be carried out on 40% of offered quantity and so on.*

**1.1.11.2** The supply of equipment/stores/services shall strictly adhere to the package discipline as described in the Purchase/Work Order. A particular item mentioned would deem to have been received in full only if all the parts/ components, installation material etc. are supplied as a package during Scheduled Delivery Period.

**1.1.11.3** All equipment supplied shall be new products only and no refurbished equipment shall be supplied in any case.

- 1.1.11.4** In case of any Quality issue, the bidder shall be required to replace the defective/inferior material, in full, by good material duly passed by QA.
- 1.1.11.5** A quality manual describing the QA system shall be submitted along with the bid, which should include the details about the component quality assurance and quality system practices, including data on critical components.
- 1.1.11.6** The Bidder shall obtain approval from ITIL/CGM (Bharat Net), BSNL Corporate Office for all the passive items to be supplied under the contract (MAF and TSEC/ QF-103 for passive items are not required to be submitted along with bid). The bidder shall submit a request enclosed with valid MAF (in the format as per tender) and copy of TSEC to CGM (Bharat Net), BSNL CO, New Delhi for approval of an OEM.
- 1.1.11.7 QA Charges:** The bidder shall get the QA done for all the material to be used for which specifications have been defined. The successful bidder shall pay the required QA charges (1% of the material cost) to BSNL QA Circle and will get the reimbursement of the same from ITIL on submission of the invoice for the same.

#### **1.1.12 RIGHT OF WAY**

- 1.1.12.1** Based on approved survey reports, the bidder is permitted to apply and obtain the Right of Way for the Project from the State Government and other agencies from the Appointed Date.
- 1.1.12.2** The bidder shall apply for and obtain the Right of Way for the Project which shall include making and filing applications, generation of demand note (DN), liaising with Government Instrumentalities and agencies etc. The bidder shall submit the DN to ITI and ITI will pay the ROW charges directly to the ROW agencies.
- 1.1.12.3** The bidder shall not be required to pay Right of Way access charges for the Project during the Contract Period to the State Government (s) or its agencies. Further, any other costs associated with the Right of Way which are beyond the scope of the agreement between the State Government and DoT/ USOF/ BSNL shall be reimbursed by ITIL, subject to submission of valid proof of payment by the bidder. This includes applicable charges for Right of Way from Government Instrumentalities regulating forest land, railway lines, defence areas, highways, oil and gas pipelines or any other agencies or departments.
- 1.1.12.4** Further, it is being expressly agreed and understood that DoT/ USOF/ BSNL or the State Government shall have no liability whatsoever in respect of survey carried out or work undertaken by the bidder on or about the Site (Route) of the OFC Network pursuant hereto in the event of Termination or otherwise.

**1.1.12.5** BSNL/ITIL shall relax the penalties on delay due to ROW permissions with proper justification. No penalty shall be levied due to delay in RoW due to any reason whatsoever if the same is not solely attributable to the bidder.

**1.1.12.6** It is expressly agreed that the license granted hereunder with respect to Right of Way for the Project shall terminate automatically and forthwith, without the need for any action to be taken by ITI/BSNL to terminate the license, upon the Termination of this Agreement for any reason whatsoever.

**1.1.12.7** It is hereby clarified that the provisions of this Clause shall apply mutatis mutandis for any additional Right of Way that may be required for the Project in accordance with the provisions of this Agreement, and upon procurement thereof, such Right of Way shall form part of the Project, as the case may be.

\*\*\*\*\*

**PART-A****TECHNICAL SPECIFICATIONS AS PER TEC GR**

S. No.	Type of Material	Technical Specifications
1.	Installation Accessories and fixtures of Self-Supporting Metal free Optical Fibre Cable	TEC GR Standard No.: TEC 87060:2017, with latest amendments if any
2.	Tension/Suspension Pole Assembly Set	TEC GR Standard No.: TEC 87060:2017, with latest amendments if any
3.	Electronic Locator System	TEC GR Standard No.: 73070:2014

**Note:**

- The technical and functional specifications mentioned in tender are mandatory and also supersede GR for the clauses where there is any change.
- The tension pole and Suspension pole accessories shall be from any one of the following approved **MAF only**.
  - ❖ Manifold
  - ❖ Veekay
  - ❖ Eritech
  - ❖ Siddhi Vinayaka Optical Networks
- If any item is not covered in the table above, the TSEC applicability shall be decided by BSNL, as per prevalent guidelines of the BSNL QA circle.

\*\*\*\*\*

**PART-B:****TECHNICAL SPECIFICATIONS FOR 8.0/7.0-meter LONG GI POLE WORKING LOAD OF 115Kgs**

The specification covers manufacture, testing and supply of 8.0/7.0-meter-long GI poles, are generally as per drawing enclosed with the specification and are intended to be used. The materials manufactured shall conform strictly to the requirement of relevant INDIAN STANDARDS and latest addition of IS using the best quality of materials and workmanship.

1.0% of the total number of poles ordered and selected at random shall be tested as per the BIS standard referred above. The bidder or the manufacturer of poles shall offer a lot of up to 500 poles to BSNL QA team for testing. The QA team will draw a sample of 1% of the offered lot and carry out the tests as per test standards referred above.

The tests for which the test facilities are available at the manufacturer premises may be carried out and

tests for which test facility is not available in the manufacturer premises, sample may be sent to external lab. After testing the offered lot may be cleared by BSNL QA based on test results as per norms of QA.

No payments will be made for the poles, which fail or tested to destruction.

Earthing shall be provided for the poles. By having a continuous separate length of SWG GI wire and the ends of wire left projecting from the narrower end of the poles and 150mm below the ground level. The arrangements for termination of the earth wire to the bolt and nut shall be as per common industry practice. The G.I. Wire used for embedding shall comply with requirement of IS:2141/1968.

The poles shall be clearly and indelibly marked with the following particulars, during manufacture but before testing at a position so as to be easily seen after erection in position.

- a. Month and year of manufacture
- b. Maker's Sl. No. and marking
- c. Purchase order No. and date
- d. A line to indicate the depth of planting
- e. BHARATNET engraved (letters – OWNER)

Provisions for holes for fixing the cross arms and other fixtures shall conform to the industry construction practice. The universal pole clamp and ADSS accessories are to be used for slinging of ADSS OFC as per E.I

Regarding ADSS OFC implementation, GI poles shall be used as per BIS standard No. IS-2713.

- 7 mtr GI pole as per 410 SP 03
- 8 Mtr GI pole as per 410 SP 13

Although, 7/8 Meter poles are mentioned in the RFP, the bidder has to provide suitable pole height or by any suitable method, approved by the authority, at road crossing, railway crossing etc. to enable the clearance of vehicles/wagons. No additional payment will be made by ITIL in this regard.

The materials manufactured shall conform strictly to the requirement of relevant INDIAN STANDARDS and latest addition of IS using the best quality of materials and workmanship. The universal pole clamp and ADSS accessories are to be used for slinging of ADSS OFC as per E.I

The tension pole and Suspension pole accessories shall be from any one of the following approved **MAF only.**

- Manifold
- Veekay
- Eritech
- Siddhi Vinayaka Optical Networks

\*\*\*\*\*

## **PART-C**

### **ENGINEERING INSTRUCTIONS (E.I.)**

#### **C1- Engineering Instructions for Under Ground Optical Fiber Cable Laying Works**

##### **SCOPE**

The Engineering Instructions spelt out in this document deal with the methods to be adopted for underground Optical Fiber Cable laying in PLB HDPE ducts and termination of OF Cables at Gram Panchayats (GPs) for BharatNet Projects. The methods of underground OFC laying included in this EI are

1. Open trenching method
2. Horizontal drilling method (HDD)

Under this RFP have been taken irrespective of the method used for OFC laying, therefore bidder has to adopt any of the above method depending upon the feasibility, time frame, meeting SLA over the contract period and O&M. The bidder has to follow the guidelines for open trenching method or HDD method adopted by bidder as under.

##### **OF CABLE LAYING APPROACH**

On the basis of the survey reports provided by ITIL and further approved by ITIL/BSNL, routes for OF cable laying shall be finalized. Road Cutting Permission shall be obtained by the bidder from respective authorities for laying the Optical Fiber Cable along the finalized roads and at rail / road crossing along the route. Generally, O.F. Cable may preferably be laid straight as far as possible along the road near the boundaries, away from the burrow pits. When the O.F. Cable is laid along the National Highways, Cable should run along the road land boundary or at a minimum distance of 15 meters from the center line of the road where the road land is wider as the OFC carries high capacity traffic and is planned for about 25 to 30 years of life. It is essential that the cable is laid after obtaining due permission from all the concerned authorities to avoid any damage (which may result in disruption of services / revenue loss) and shifting in near future due to their planned road widening works. For obtaining RoW permission, BSNL/ITI will facilitate the bidder.

In special cases where it may be necessary to avoid burrow pits or low lying areas, the Cable may be laid underneath the shoulders at a distance of 0.6 meter from the outer edge of the road embankment provided the same is located at least 4.5 meters away from center line of road.

##### **GENERAL**

###### **Soil Classification**

Soil shall be classified under two broad categories Rocky and Non-Rocky. The soil is categorized as rocky if the cable trench cannot be dug without blasting and / or chiseling. All other types of soils shall be categorized as Non-Rocky including Murrum & soil mixed with stone or soft rock.

### **Rocky soil**

The terrain which consists of hard rocks or boulders where blasting/ chiseling is required for trenching such as quartzite, granite, basalt in hilly areas and RCC (reinforcement to be cut through but not separated) and the like.

### **Non-Rocky soils**

This will include all types of soil- soft soil/hard soil/Murrum i.e. any strata, such as sand, gravel, loam, clay, mud, black cotton Murrum, shingle, river or nullah bed boulders, soiling of roads, paths etc. (All such soils shall be sub-classified as kachcha soil) and hard core, macadam surface of any description (water bound, grouted tarmac etc.), CC roads and pavements, bituminous roads, bridges, culverts (All such soils shall be classified as Pucca soils).

The Optical Fiber Cable shall be laid through PLB HDPE Ducts buried at a nominal depth of 165cm. The steps involved in OF Cable laying are as under

- Excavation of trench up to a nominal depth of 165 cm in non-Rocky soil, according to construction specifications along National/State Highways/other roads and in built up /rural areas. Under exceptional conditions/ genuine circumstances due to site constraints/ soil conditions, relaxation can be granted by the competent authority for excavation of trench to a depth lesser than 165cm. Such relaxation shall be given as per the laid down norms/ procedures being set by ITIL/BSNL and with the approval of the competent authority.
- The payment in such cases shall be made on pro-rata basis as per the laid down rates mentioned in the tender under the head “**Rates payable in case of laying at less depth**”.
- Laying of PLB HDPE Ducts/coils coupled by sockets in excavated trenches, on bridges and culverts, as per construction specification and sealing of PLB HDPE Ducts pipe ends at every manhole/ joint chamber by end-plugs of appropriate size. Providing additional protection by GI pipes and/or concreting/chambering, wherever required according to construction specification mentioned in the tender.
- Fixing of GI pipes/troughs with clamps on culverts/bridges and/or chambering or concreting of G.I. Pipes/troughs, wherever necessary.
- Laying Protection Pipes on Bridges and Culverts. In case trenching and pipe laying is not possible on the culverts, the pipes shall be laid on the surface of the culverts/bridges after due permission from the competent authority within the concerned ITIL/BSNL as per construction specification and CC may be done over the pipe for protection.
- Back filling and Dressing of the Trench according to construction specifications.
- Making manhole/joint chamber of size (1.0 m length x 1.0 m width x 1.65 m Depth) at every Cable pulling location for housing the OF Cable loop & Pulling Optical Fiber Cable using proper tools and accessories. Sealing of both ends of the PLB HDPE pipe in manhole/joint chamber by hard rubber bush of suitable size to avoid entry of rodents into the PLB HDPE Ducts, putting split PLB HDPE Ducts and split RCC pipes with proper fixtures over cable in the manhole to protect the bare

cable. Digging of pit of size 2-meter x 2-meter x 1.8 meter (depth) for fixing of Jointing chambered-cast RCC cover or stone of suitable size on jointing chamber to protect the Joint and backfilling of jointing chamber with excavated soil.

- Digging of pits 500 cm to 1000 cm towards jungle side at every jointing chamber along the route to a depth of 75cm fixing of route Indicator/joint indicator, concreting and backfilling of pits. Painting of route indicators with **Blue colour and joint Indicator by Grey color** and sign writing denoting route/joint indicator number and marked as “BBNL/BSNL” as per construction specifications. Alternatively, electronic markers shall be used for joint indicators by fixing/tying them to joint closure.

## **SPECIFICATIONS OF MATERIALS TO BE USED**

### **PLB HDPE Duct**

Optical Fiber Cables should be pulled through Permanently Lubricated HDPE Duct of 40mm/33 mm size conforming to the specifications as per TEC/GR 72030:2019 with latest Amendments. The Ducts shall be blue in color and have the identification markings as per TEC GR wherein BSNL logo shall be marked as BSNL's name.

### **PLB HDPE Duct Accessories Push fit Coupler**

Push Fit couplers shall be used for coupling PLB HDPE ducts/coils. The specifications of the couplers shall be as per GR no TEC/GR 72030:2019 with latest amendments.

### **PP Rope**

PP Rope should conform to GR No. TEC/GR 72030:2019 with latest Amendments. However, this is optional and bidder may use the same on need basis. The PP rope can be ordered along with the PLB duct as required. In this case PP ropes drawn through the HDPE/PLB pipes/coils and safely tied to the end caps at either ends with hooks to facilitate pulling of the OF cables at a later stage. The rope used is 3 strands Polypropylene Para Pro rope having yellow color and size of 6 mm diameter. It should have a minimum breaking strength of 550 kgs. The length of each coil of rope should be 5 meter more than the standard length of duct (or as ordered) and it should conform to (i) BS 4928 Part-II of 1974 (ii) IS 5175 of 1982. It should be of special grade and should have ISI certificate mark. It should be manufactured out of industrial quality Polypropylene.

### **End Cap**

End Cap shall be used for sealing the ends of the empty ducts, prior to installation of the OF Cable and shall be fitted immediately after laying the duct to prevent the entry of any dirt, water, moisture, insects/rodents etc. It should conform to GR No. TEC/GR 72030:2019 with latest amendments. The ends of the PLB HDPE ducts/coils laid in the manholes should be closed with End Caps. The End Caps used should be suitable for closing 40mm/33mm PLB HDPE ducts/coils. A suitable arrangement should be provided in the End Cap to tie PP Rope.

### **Cable sealing Plug**

This shall be used to seal the end of the ducts perfectly, after the OF cable is pulled in the duct. For pulling the cable through the ducts, it is necessary to provide manholes at that location and also at bends and corners wherever required. The ends of the PLB HDPE ducts/coils are closed with Cable Sealing Plugs. The End Plugs used should be suitable for closing 40mm/33mm PLB HDPE ducts/coils. The Cable sealing plug shall conform to GR No TEC/GR 72030:2019 with latest amendments. (Wherever blowing technique is used for laying OF Cable, at the discretion of the BIDDER concerned, the hand holes/manholes required for accessing the cable during cable laying can be at longer distances depending upon requirement.)

### **Material for Providing Additional Protection**

**RCC Full Round Pipes:** Reinforced cement concrete pipes (spun type) coupled with RCC collars sealed with cement mortar used to provide additional protection to PLB HDPE Ducts/coils at lesser depths should be of full round, NP-2 class and size 100 mm (internal diameter), conforming to IS standard 458- 1988 with latest amendments. The pipes should have a nominal length of 2 meters.

The RCC collars should be properly sealed using cement mortar 1:3 (1:53 grade cement of reputed brand, 3: fine sand without Impurities). In case of long spans, every third joint will be embedded in a concrete block of size 60 cm (L) x 40cm (W) x 25 cm (H) of 1:2:4 cement concrete mix (1: cement, 2: coarse sand, 4: stone aggregate of 20 mm nominal size) so that the alignment of RCC pipes remain firm and intact. Also, both ends of RCC pipes spans will be sealed by providing concrete block of size 40 cm (L) x 40 cm (W) x 25 cm (H) of 1:2:4 cement concrete mix to avoid entry of rodents.

**RCC Split Pipes:** The split Reinforced cement concrete pipes (spun type) with in-built collars are used to provide additional protection to PLB HDPE Ducts/coils should be of 100mm internal dia.(Spotted), Class-NP-3, Thickness: 25mm, Length: 2 Meters with inbuilt collar at one end, conforming to ISI Specification IS: 458, 1988 with latest amendment.

**G.I. Pipes:** G.I. pipes should be of medium duty class having inner diameter of 50mm and should conform to specifications as per IS 554/1985 (revised up to date) IS 1989 (Part- I), 1900 Sockets (revised up to date) & IS 1239 (Part-II) 1992 (revised up to date).

**DWC Pipes:** Use of normal duty DWC (Double walled corrugated) HDPE pipe conforming to TEC GR no.GR/ with latest amendments shall be preferably utilized as first choice for protection of Optical Fiber Cable instead of GI pipes. The DWC pipes used shall be of size 75/61mm as per table 2 of the said TEC GR.

**M.S. Weld Mesh:** The PLB HDPE Ducts can also be protected by embedding it in concrete of size of 25 cm x 25 cm reinforced with MS weld mesh. The MS weld mesh used should be of 50 mm x 100mm size, 12 SWG, 120 cm in width in rolls of 50m each. One meter of MS weld Mesh caters to approx. 3 meters of concreting (See figure '2' for details). The strength of RCC/CC is dependent on proper curing, therefore, it is imperative that water content of CC/RCC mix does not drain out into the surrounding soil. In order to ensure this, the RCC/CC work should be carried out by covering all the sides by yellow PVC sheets of weight

not less than 1 kg per 8 sqm to avoid seepage of water into the soil.

**Joint Chamber:** The Joint chamber shall be provided at every joint location to keep the OF cable joint well protected and also to house extra length of cable which may be required in the event of faults at a later date. The Joint chamber shall be of pre-cast RCC type as per construction specification. Brick chamber can also be made with prior permission of ITIL/BSNL.

**Rubber Bush:** To prevent entry of rodents into PLB HDPE DUCTS, the ends of PLB HDPE DUCTS are sealed at every manhole and joint using rodent resistant hard rubber bush (cap) after optical Fiber cable is pulled. The rubber bush should be manufactured from hard rubber with grooves and holes to fit into 40 mm PLB HDPE DUCTS pipe, so that it should be able to prevent the entry of insects, rodents, mud, and rainwater into the PLB HDPE DUCTS pipe. It should conform to TEC GR with latest amendments. (See Figure-3)

**Route/Joint Indicator:** The Route/Joint indicators are co-located with each manhole/joint chamber. In addition, Route indicators are also to be placed where route changes direction like road crossings etc. Either RCC/Pre-cast or Stone based route indicators can be used. The detailed specification and design of the same shall be as per construction specification. Generally, Stone Route indicators shall be used for the Bharat Net Project. Alternatively, electronic markers shall be used for joint indicators by fixing/tying them to joint closure.

## EXCAVATION OF TRENCHES

### Trenching

**Location and Alignment of the Trench:** In built up areas, the trench will normally follow the foot-path of the road except where it may have to come to the edge of the carriage way cutting across road with specific permissions from the concerned authorities maintaining the road (such permissions shall be obtained by the department as per MOU signed with respective State Govt.). Outside the built up limits the trench will normally follow the boundary of the roadside land. However, where the road side land is full of burrow pits or afforestation or when the cable has to cross culverts/ bridges or streams, the trench may come closer to the road edge or in some cases, over the embankment or shoulder of the Road (permissions for such deviations for cutting the embankment as well as shoulder of the road shall be obtained). The alignment of the trench will be decided by a responsible official of the ITIL/BSNL. Once the alignment is marked, no deviation from the alignment is permissible except with the approval of ITIL/BSNL. While marking the alignment only the center line will be marked and the bidder shall set out all other work to ensure that, the excavated trench is as straight as possible. The bidder shall provide all necessary assistance and labor, at his own cost for marking the alignment. Bidder shall remove all bushes, undergrowth, stumps, rocks and other obstacles to facilitate marking the center line without any extra charges. It is to be ensured that minimum amount of bushes and shrubs shall be removed to clear the way and the bidder shall give all, consideration to the preservation of the trees.

The line-up of the trench must be such that PLB pipe(s) shall be laid in a straight line, both laterally as well

as vertically except at locations where it has to necessarily take a bend because of change in the alignment or gradient of the trench, subject to the restrictions mentioned elsewhere.

Line-Up: The line-up of the trench must be such that PLB HDPE Ducts shall be laid in a straight line except at locations where it has to necessarily take a bend because of change in the alignment or gradient of the trench, subject to the restrictions mentioned elsewhere.

### **Method of Excavation**

In built up areas, the bidder shall resort to use of manual labor / HDD only to ensure no damage is caused to any underground or surface installations belonging to other public utility services and/or private parties. However, along the Highways and cross country there shall be no objection to the bidder resorting to mechanical means of excavation, provided that no underground installations existing the path of excavation, if any, are damaged.

There shall be no objection to resort to horizontal boring to bore a hole of required size and to push through G.I. Pipe (50 mm ID) through horizontal bore at road crossing or rail crossing or small hillocks etc.

All excavation operations shall include excavation and 'getting out'. 'Getting out' shall include throwing the excavated materials at a distance of at least one meter or half the depth of excavation, whichever is more, clear off the edge of excavation. In all other cases 'getting out' shall include depositing the excavated materials as specified.

In Rocky strata excavation shall be carried out by use of electro mechanical means like breakers/ jack hammers or by blasting wherever permissible with express permission from the competent authority. If blasting operations are prohibited or not practicable, excavation in hard rock shall be done by chiseling / jack hammers.

Trenching shall as far as possible be kept ahead of the laying of pipes. bidder shall exercise due care that the soil from trenching intended to be loose for back filling is not mixed with loose debris. While trenching, the bidder should not cause damage to any underground installations belonging to other agencies and any damage caused should be made good at his own cost and expense.

Necessary barricades, night lamps, warning board and required watchman shall be provided by the bidder to prevent any accident to pedestrians or vehicles. While carrying out the blasting operations, the bidder shall ensure adequate safety by cautioning the vehicular and other traffic. The bidder shall employ sufficient man-power for this with caution boards, flags, sign writings etc.

The bidder should provide sufficient width at the trench at all such places, where it is likely to cave in due to soil conditions without any extra payment. A minimum free clearance of 15 cm should be maintained above or below any existing underground installation. No extra payment will be made towards this. In order to prevent damage to PLB HDPE DUCTS over a period of time, due to the growth of trees, roots, bushes, etc., the bidder shall cut them when encountered in the path of alignment of trench without any additional charges.

In large burrow pits, excavation may be required to be carried out for more than 165 cm in-depth to keep gradient of bed less than 15 degrees with horizontal. If not possible as stated above, alignment of trench shall be changed to avoid burrow pit completely.

The trenching length will be calculated based on the rodometer distance for payment purpose.

### **Depth and Size of the Trench**

The depth of the trench from top of the surface shall not be less than 165 cm unless otherwise relaxation is granted by ITIL/BSNL under genuine circumstances.

In rocky terrain, less depth shall be allowed only in exceptional circumstances with additional protection where it is not possible to achieve the normal depth due to harsh terrain/ adverse site conditions encountered. This shall be done only with the approval of the ITIL/BSNL. This shall be properly documented. In all cases, the slope of the trench shall not be less than 15 degrees with the horizontal surface. The width of the trench shall normally be 45 cm at the top & 30 cm at the bottom.

In case, additional pipes (HDPE/GI/RCC Pipes) are to be laid in some stretches, the same shall be accommodated in this normal size trench.

When trenches are excavated in slopes, uneven ground and inclined portion, the lower edge shall be treated as top surface of land and depth of trench will be measured accordingly. In certain locations, such as uneven ground, hilly areas and all other Places, due to any reason whatsoever it can be ordered to excavate beyond standard depth of 165 cm to keep the bed of the trench as smooth as possible. Near the culverts, both ends of the culverts shall be excavated more than 165 cm to keep the gradient less than 15 degree with horizontal. For additional depth in excess of 165 cm, no additional payment shall be applicable.

If excavation is not possible to the minimum depth of 165 cm, as detailed above, full facts shall be brought to the notice of the ITIL/BSNL in writing giving details of location and reason for not being able to excavate that particular portion to the minimum depth.

Approval shall be granted by the ITIL/BSNL in writing under genuine circumstances. The decision of the ITIL/BSNL shall be final and binding on the bidder. All the relaxations granted as specified above shall be dealt with as per the laid down norms and procedure of ITIL/BSNL.

### **Dewatering**

The bidder shall be responsible for all necessary arrangements to remove or pump out water from trench. The bidder should survey the soil conditions encountered in the section and make his own assessment about dewatering arrangement that may be necessary. No extra payment shall be admissible for this.

### **Wetting**

Wherever the soil is hard due to dry weather conditions, if watering is to be done for wetting the soil to make it loose, the same shall be done by the bidder. No extra payment shall be admissible for this.

### **Blasting**

For excavation in hard rock, where blasting operations are considered necessary, the bidder shall obtain approval of the ITIL/BSNL in writing for resorting to blasting operation. The bidder shall obtain license from the ITIL/BSNL for undertaking blasting work as well as for obtaining and storing the explosive as per the Explosive Act, 1884 as amended up to date and the explosive Rules, 1983. The bidder shall purchase the explosives fuses, detonators, etc. only from a licensed dealer. Transportation and storage of explosive at site shall conform to the aforesaid Explosive Act and Explosive Rules. The bidder shall be responsible

for the safe custody and proper accounting of the explosive materials.

Fuses and detonators shall be stored separately and away from the explosives. ITIL/BSNL or his authorized representatives shall have right to check the bidder's store and account of explosives. The bidder shall provide necessary facilities for this.

The bidder shall be responsible for any damage arising out of accident to workmen, public or property due to storage, transportation, and use of explosive during blasting operation. Blasting operations shall be carried out under the supervision of a responsible authorized agent of the bidder, during specified hours as approved in writing by the ITIL/BSNL. The authorized agent shall be conversant with the rules of blasting. All procedures and safety precautions for the use of explosives drilling and loading of explosives before and after shot firing and disposal of explosives shall be taken by the bidder as detailed in IS: 4081 safety code for blasting and related drilling operation.

### **Trenching Near Culverts/ Bridges**

The PLB HDPE Ducts shall be laid in the bed of culvert at the depth not less than 165 cm protected by RCC pipes as decided by ITIL/BSNL. Both ends of culverts shall be excavated more than 165 cm in depth to keep the gradient of not less than 15 degrees with horizontal. The bed of trench should be as smooth as possible.

While carrying out the work on bridges and culverts, adequate arrangement for cautioning the traffic by way of caution boards during day time and danger lights at night shall be provided. In case of small bridges and culverts, where there is a likelihood of their subsequent expansion and remodeling, the cable should be laid with some curve on both sides of the culvert or the bridge to make some extra length available for readjustment of the cable at the time of reconstruction of culvert or the bridge.

### **Laying of PLB HDPE Ducts**

After the trench is excavated to the specified depth, the bottom of the trench has to be cleared of all stones or pieces of rock and levelled up properly. A layer of soft soil/or sand (in case the excavated material contains sharp pieces of rock/stones) of not less than 5 cm is required for levelling the trench to ensure that the cable when laid will follow a straight alignment. Adequate care shall be exercised while laying so that the OF cables are not put to undue tension/pressure after being laid as this may adversely affect the optical characteristics of cables with passage of time.

The bidder shall ensure that trenching and pipe laying activities are continuous, without leaving patches or portions incomplete in between. In case intermediate patches are left, measurement of the completed portions will be taken only after work in such left-over patches are also completed in all respects.

Preparatory to aligning the pipe for jointing, each length of the PLB HDPE Ducts shall be thoroughly cleaned to remove all sand, dust or any other debris that may clog, disturb or damage the optical Fiber cable when it is pulled at a later stage. The ends of each pipe and inside of each Socket shall be thoroughly cleaned of any dirt or other foreign materials.

After the trench is cleaned the PLB HDPE Ducts/Coil shall be laid in the cleaned trench, jointed with Sockets. Drawing up of PP rope is optional as per TEC GR. In case of use of PP Rope, at every manhole or approximately at every 200m or at bends or turns the PP rope will be tied to the HDPE end caps used for sealing the PLB HDPE Ducts, to avoid entry of rodents/mud etc.

At the end of each day work, the open ends of the pipe's sections shall be tightly closed with end caps to prevent the entry of dirt/mud, water or any foreign matter into PLB HDPE Ducts until the work is resumed. In built up area falling within Municipal/Corporation limits, the PLB HDPE Ducts shall be laid with protection using RCC Pipes/ Concreting reinforced with weld mesh (only in exceptional cases).

For lesser depths requiring additional protection in built up areas, towns and cities falling within the municipal limits, suitable protection shall be provided to PLB HDPE pipes/coils using RCC/DWC full round/split pipes or GI pipes or cement concreting reinforced with MS weld mesh or a combination of any of these as per the site requirement. This shall be done only with the prior instructions/approval of the ITIL/BSNL. The specifications for providing each of these protections are given later in this document. Moreover, in cross country routes, if depth is less than 1.2 meters, protection by using DWC Pipe shall be provided. ITIL/BSNL shall decide about such stretches and type of protection to be provided in view of the site requirements. Normally 63 / 100 mm DWC Pipes shall be used for protecting PLB HDPE Ducts but if more than one PLB pipe is to be laid and protected, DWC Pipe of suitable size to accommodate the required number of PLB Pipes shall be used.

The PLB HDPE Ducts shall be laid in RCC Full Round spun Pipes/GI Pipes as required at Road crossings. The RCC pipes/GI pipes shall extend at least 3 meters on either side of the road at Road crossings. At Road crossings, extra GI/PLB HDPE Ducts may be laid as per the direction of the ITIL/BSNL. On Rail bridges and crossings, the PLB HDPE Ducts shall be encased in suitable cast iron as prescribed by the Railway Authorities. Wherever RCC pipes are used for protection, the gaps between the RCC collars and the RCC pipes shall be sealed using cement mortar 1:3 (1:53 grade cement of reputed brand, 3: fine sand without impurities) to bar entry of rodents. Every third collar of RCC pipes (normally of 2 meters length) and also both ends of RCC Pipes will be embedded in a concrete block of size 40 cm (L)x 40 cm(W) x 25 cm (H) of 1:2:4 cement concrete mix (1:53 grade cement of reputed brand, 2: coarse sand, 3: stone aggregate of nominal size of 20 mm) so that the alignment of RCC pipes remain firm and intact and to avoid entry of rodents. Wherever GI pipes are used, special care should be taken to ensure that G.I. Pipes are coupled properly with the sockets so as to avoid damage to PLB pipe and eventually the OF Cable in the event of pressure coming on the joint and G.I. Pipe joint giving its way. Rubber bushes shall be used at either ends of the GI pipes to protect PLB pipe. Both the ends of G.I. Pipe will be embedded in a concrete block of size 40 cm (L) x 40 cm ((W) x 25 cm (H) of 1:2:4 cement concrete mix (1:53 grade cement of reputed brand, 2: coarse sand, 3: stone aggregate of nominal size of 20 mm) so that the alignment of G.I. Pipes remain firm and intact and to avoid entry of rodents.

In case of protection by concreting at site, the nominal dimension of concreting shall be 250 mm x250 mm section. Cement Concrete Mixture used shall be of 1:2:4 compositions i.e. 1:53 grade Cement of a reputed company, 2: Coarse Sand, 4: Graded Coarse Stone aggregate of 20 mm nominal size, reinforced with MS weld mesh. As the RCC is cast at site, it is imperative to ensure that special care is taken to see that proper curing arrangements are made with adequate supply of water. The bidder shall invariably use mechanical mixer at site for providing RCC protection, to ensure consistency of the mix.

For carrying out concreting work in trenches, yellow PVC sheets of width not less than 1.0 M and of weight not less than 1 kg. Per 8 sq. meters shall be spread and nailed on sides of the trench to form trapezoidal section for concreting in the cleaned trench, to avoid seepage of water into the soil.

A bed of cement concrete mixture of appropriate width and 75 mm thickness shall be laid on the PVC sheet,

before laying PLB HDPE ducts. The PLB HDPE Ducts shall then be laid above this bed of concrete. After laying the PLB HDPE Ducts, MS weld mesh is wrapped around and tied and concrete mix is poured to form the cross sectional dimensions as instructed by the ITIL/BSNL.

The strength of RCC is dependent on proper curing therefore, it is imperative that water content of RCC mix does not drain out into the surrounding soil. Portions where cement concreting has been carried out shall be cured with sufficient amount of water for reasonable time to harden the surface. After curing, refilling of the balance depth of the trench has to be carried out with excavated soil.

The PLB HDPE Ducts/RCC/GI Pipes shall be laid only in trenches accepted by ITIL/BSNL or his representative. The bidder shall exercise due care to ensure that the PLB HDPE Ducts are not subjected to any damage or strain.

Water present in the trench at the time of laying the PLB HDPE Ducts shall be pumped out by the bidder before laying the pipes in the trench to ensure that no mud or water gets into the pipes, thus choking it. In case of nallahs, which are dry for nine months in a year, the PLB HDPE Ducts shall be laid inside the RCC Pipes laid at a minimum depth of 165 cm, as instructed by the ITIL/BSNL. The mechanical protection shall extend at least 5 meters beyond the bed of nallah on either side.

Notwithstanding anything contained in clauses referred above, the ITIL/BSNL may order, based on special site requirements, that the PLB HDPE Ducts may be encased in reinforced cement concrete, as detailed, in the tender document. While laying the pipes, a gap of 2 M is kept at convenient locations approx. 200 m apart and at the bends and turns, which will be used as manholes during OF cable pulling. Ends of the PLB HDPE Ducts at the manholes shall be sealed using end caps after tying the PP rope to the end caps to avoid choking of the pipes. In a similar manner, manholes shall be kept while approaching bridges, road crossings etc., as instructed by the ITIL/BSNL. The location of the manholes will be decided by the ITIL/BSNL.

#### **Laying Protection Pipes on Bridges and culverts**

In case trenching and pipe laying is not possible on the culverts, the pipes shall be laid on the surface of the culverts/bridges after due permission from the ITIL/BSNL. Of late the bridge construction authorities are providing channel ducts on the footpaths on the bridges for various services. The RCC/DWC/ G.I. Pipes can be laid in these ducts for pulling cables. However, for laying cables on existing bridges, where duct arrangement does not exist, one of the following methods may be adopted.

- In case of the Bridges/Culverts, where there are no ducts and where the cushion on the top of the Arch is 50 cm to 100 cm or more, G.I. Pipe (Carrying PLB HDPE pipe and cable) may be buried on the top of the Arch adjoining the parapet wall, by digging close to the wheel guards. Every precaution shall be taken to see that no damage occurs to the arch of the culvert. After burying the GI pipe, the excavated surface on the arch shall be restored.
- Where the thickness of the Arch is less than 50 cm, the pipe must be buried under the wheel guard masonry and the wheel guard rebuilt.
- If neither of the above two methods is possible, the G.I. Pipes/GI Troughs must be clamped on the parapet wall with the clamps. If necessary, the pipes may be taken through the parapet wall at the ends where the wall diverges away from the road.

Methods cited in above clauses should be carried out under close supervision of Road authorities. The surface to be concreted should be thoroughly cleaned and levelled before concreting. At both ends of the Bridges/Culverts, where the GI Pipes /GI Troughs slope down and get buried, the concreting should be extended sufficiently to ensure that no portion of the GI Pipes/GI Troughs is exposed as approved by the ITIL/BSNL to protect the pipe/trough from any possible externally caused damage.

Where white wash/colour wash is existing on the Bridges/ Culverts, the same should also be carried out on the concreted portion to ensure uniformity.

### **Black Filling and Dressing of the Trench**

Provided that the PLB HDPE pipes have been properly laid in the trench at the specified depth, the back filling operation shall follow as early as practicable. The earth used for filling shall be free from all roots, Grass, shrubs, vegetation, trees, saplings and any other kind of garbage or pebbles. The back filling operation shall be performed in such a manner so as to provide firm support under and above the pipes and to avoid bend or deformation of the PLB HDPE pipes when the pipes get loaded with the back filled earth.

At locations where the back filled materials contains stones/sharp objects which may cause injury to the PLB HDPE pipes and where the excavated or rock fragments are intended to refill the trench in whole or in part, the trench should be initially filled, with a layer of ordinary soil or loose earth (free from any stones/pebbles) not less than 10 cm thick over the pipes.

Back filling on public, roads, railway crossings, footpaths in city areas shall be performed immediately after laying the HDPE pipes. Back filling at such locations shall be thoroughly rammed, so as to ensure original condition so that it is safe for the road traffic. All excess soil/ material left on road/ footpath/railway crossing shall be removed by bidder. However, along the highways and in country side, the excess dug up material left over after refilling should be kept in a heap above over the trench.

In city limits, at any given time not more than 50 Meters length of trench should be kept open and in all places where excavation has been done, no part of the trench should be kept open over night to avoid occurrence of any mishap or accident in darkness.

### **Restoration of Road Surface**

Road restoration work to be made with bituminous macadam for semi grouting 50 mm thick and premix carpet surfacing 25 mm thick over the grouted surface (total up to 75 mm thick) including supply of asphalt etc. to evenly match the road, including consolidation and rolling as per standard specification of DSR 1997 Road restoration work with cement concrete 1:4:8 mix for thickness varying from 150 mm to 225 mm, including supply of concrete to be made to evenly match the road.

### **CABLE PULLING AND JOINING/SPLICING**

## **CABLE PULLING/BLOWING**

Manholes/Joint chambers marked during PLB HDPE Ducts pipe laying of approx. size of 1.0 m length x 1.0 m width x 1.65 m depth shall be excavated for pulling the cables. There may be situations where addition manholes/joint chambers are required to be excavated, for some reasons, to facilitate smooth pulling of cable. Excavation of addition manholes will be carried out, without any extra cost. De-watering of the manhole, if required, will be carried out without any extra costs. Dewatering/ De- gasification of the Ducts, if required, will be carried out without any extra costs.

The Optical Fiber cables are available in drums in lengths of approx. 2 km. The cables shall be blown / manually pulled (in exceptional cases) through already laid PLB HDPE DUCTS. This work is to be carried out under the strict supervision of site in-charge. It shall be ensured that during the blowing / pulling of Cable the tension is minimum and there is no damage to the Cable/Optical Fibers.

After pulling of the drum is completed, both ends of the PLB HDPE DUCTS pipe in each Manhole should be sealed by hard rodent resistant rubber bush, to avoid entry of rodents/mud into PLB HDPE Ducts.

The Manholes are prepared by providing 40 mm split PLB HDPE DUCTS pipe of 2.5 to 3m length and closing the split PLB HDPE Ducts by providing necessary clamps/ adhesive tape as per the directions of ITIL/BSNL. Afterwards, the split/cut PLB HDPE DUCTS pipe are covered with 100 mm split RCC pipe of 2m length and sealing the ends of RCC pipe with lean cement solution for protecting bare cable in the manhole. After fixing of RCC Split Pipes necessary back filling/reinstatement and dressing of manholes should be carried out as referred under trenching. The location of the pulling manhole should be recorded for preparation of documentation.

## **Jointing/Splicing**

Optical Fiber Cable Joints will be at varying distances depending upon the incremental fiber to be laid for connecting Panchayats. The fibers are to be spliced at every Joint & at both ends (Terminations) in the equipment room as directed by the ITIL/BSNL. The infrastructure required for cable splicing i.e. Splicing machine OTDR. Optical talk set, Tool kit etc. will be arranged by the bidder and any additional accessories. e. g. Engine etc. required at site for splicing will also be arranged by the bidder.

The Optical Fiber Cable thus joined end-to-end will be tested by the ITIL/BSNL/TPA/IE officer of Acceptance Testing unit of the concerned ITIL/BSNL for splice losses and transmission parameters as specified by ITIL/BSNL and prevalent at that time. The through Optical Fiber should meet all the technical parameters, specified and no relaxation will be granted.

## **Construction of Jointing Chamber**

The joint chambers are provided at every joint to keep the O.F.C. joint well protected and also to keep extra length of cable, which may be, required to attend the faults at a later date. Jointing chambers are to be prepared at the Fiber Point of Interconnect (FPOI) or normally at distance of every 2 km. Actual location of jointing chamber depends on length of cable drum and appropriateness of location for carrying out jointing

work.

In case of restoration of existing made-over network and during O&M phase, the Manholes shall be provisioned only in case a long section is being replaced. Construction of manholes for attending single cuts and small section replacement is not mandatory.

The jointing chambers are constructed by way of fixing pre-cast RCC chambers/Brick Chambers and covers as per the instructions from ITI/BSNL.

### **Pre cast RCC chamber**

For fixing pre cast RCC chamber, first a pit of size 2 m x 2 m x 1.8 m depth shall be required to be dug. Pre cast RCC chamber shall consist of three parts (i) round base plate of 140 cm diameter and 5 cm thickness in two halves (ii) full round RCC joint chamber with diameter of 120 cm and height of 50 cm and thickness of 5 cm (iii) round top cover will be in two halves with diameter of 140 cm and thickness of 5 cm having one handle for each half in centre and word "BSNL OFC" engraved on it. (See figure '4'). After, fixing the pre-cast RCC joint chamber, the joint chamber is filled with clean sand before closing. Back filling of joint chamber pit with excavated soil shall be carried out in the end.

### **Brick Chamber**

For constructing brick chamber, first a pit of size 2m x 2 m x 1.8 m depth shall be required to be dug, then, base of the chamber shall be made using concrete mix of 1:5:10 (1 cement, 5 coarse sand, 10 graded stone aggregate of 40mm nominal size) of size of 1.7m x 1.7 m and 0.15 m using cement mortar mix of 1:5 (1: cement, 5: fine sand). The chamber should have internal dimensions of 1 m x 1 m and 1 m height. The bricks to be used for this purpose should be size 9"x4.5"x3", best quality available and should have smooth rectangular shape with sharp corners and shall be uniform in color and emit clear ringing sound when struck.

The joint chamber should be so constructed that PLB pipe ends remain protruding minimum 5 cm inside the chamber on completion of plastering. The PLB pipes should be embedded in wall in such a way that, the bottom brick should support the pipe and upper brick should be provided in a manner that PLB HDPE pipe remains free from the weight of the construction. The joint chamber should be plastered on all internal surfaces and top edges with cement mortar of 1:3 (1: cement, 3: coarse sand), 12 mm thick finished with a floating coat of complete cement as per standard. Pre- cast RCC slab with two handles to facilitate easy lifting, of size 0.7 m x 1.4 m and of thickness of 5 cm having one handle for each half in centre and word "OFC" engraved on it are to be used to cover the joint chamber. Two numbers of such slabs are required for one joint chamber. This pre-cast slab should be made of cement concrete mix of 1:2:4 (1: cement, 2: coarse sand, 4: stone aggregate 6 mm nominal size) reinforced with steel wire fabric 75 x 25 mm mesh of weight not less than 7.75 Kg per sq. Meter. The joint chamber is filled with clean sand before closing. Back filling of joint chamber pit with excavated soil shall be carried out in the end.

### **Fixing of Route Indicators / Joint Indicators**

Pits shall be dug 500 cm to 1000 cm towards jungle side at every Manhole and Jointing chamber for fixing

of Route/Joint Indicator. In addition, Route Indicators are also required to be placed where O.F. Cable changes directions like road crossing etc. Alternatively, electronic markers shall be used for joint indicators by fixing/tying them to joint closure.

The pits for fixing the indicator shall be dug for a size of 60 cm x 60 cm and 75 cm (depth). The indicator shall be secured in upright position by ramming with stone and murrum up to a depth of 60 cm and concreting in the ratio of 1:2:4 (1: cement, 2: coarse sand, 4 stone aggregate 20 mm nominal size) for the remaining portion of 15 cm. Necessary curing shall be carried out for the concreted structure with sufficient amount of water for reasonable time to harden the structure.

### **RCC/Pre cast Route Indicators**

The route /joint indicator made of pre-cast RCC should have the following dimensions Base - 250 mm x 150 mm Top - 200 mm x 75 mm Height - 1250 mm (See Figure-'5').

### **Stone based Route Indicators**

The route /joint indicators made of Sand/lime Stone Should have the following dimension. The word 'BBNL/BSNL OFC' should be engraved on the Route/Joint indicators.

- i. Stone to be used (Sand/lime Stone)
- ii. Indicator Top surface to be rounded
- iii. Base 155 mm × 100 mm
- iv. Upper 500 mm length to be Tapered width wise as shown in the drawing and homogeneously finished
- v. Height 650mm (Straight) + 400 mm (Tapered)
- vi. The route indicators should be engraved OFC of size 80mm length and 50mm width.
- vii. Length 3.5Ft., top 4" x 4" dressed 1Ft. from top & tapered.

(See figure '6' for details of Stone route indicators)

The Route indicators shall have painted Blue and placed at 500 to 1000 cm away from the centre of the trench towards jungle side. The Joint indicators are placed at OFC joints and placed 500 to 1000 cm away from wall of the joint chamber facing jungle side and are painted Grey. The engraved word "BBNL/BSNL OFC" should be painted in white, on route as well as joint indicators. Numbering of route indicators/joint indicators should also be done in white paint. The numbering scheme for route indicators will be Joint No./Route Indicator No. for that joint. For example, 2/6 marking on a route indicator means 6th route indicator after 2<sup>nd</sup> joint. Additional joints on account of faults at a later date should be given number of preceding joint with suffix A, B, C, and D. For example, sign writing 2A on a joint indicator means, additional joint between joint No. 2 and 3. The numbering of existing route/joint indicator should not be disturbed on account of additional joints. Enamel paints of reputed brand should be used for painting and sign writing of route as well joint indicators.

The route and joint indicator shall be painted with primer before painting with oil paint. The material used should bear ISI mark. The size of each written letter should be at least 3.5 cm. The colour of painting and sign writing is as under:

- For Joint Indicator: Grey colour**
- For Route Indicator: Blue colour**
- For BSNL OFC &Nos: White colour**

## **Documentation**

The documentation, consisting of the following shall be prepared for each Block and the Panchayats connected to the Block. 4 sets of documentation shall be provided both in Electronic format on CD as well as Hard bind copy.

Route Index Diagrams General: This diagram shall consist of Cable Route Details on Geographical Map drawn to scale with prominent land marks and alignment of cable with reference to road. This shall be prepared on A-3 sheets of 80 GSM.

Route Index Diagrams Profile: These diagrams will contain

- Make and size of the cable.
- Offset of cable from centre of the road at every 10 meters
- Depth profile of Cable at every 10 meter;
- Details of protection with type of protection depicted on it;
- Location of culvert and bridges with their lengths and scheme of laying of PLB HDPE Ducts pipe thereon.
- Important landmarks to facilitated locating the cable in future;
- Location of Joints and pulling manholes.

These diagrams shall be prepared on A-4 sheets of 80 GSM. On one sheet profile of maximum 400 meters shall be given to ensure clarity.

## **Joint Location Diagram**

This diagram will show

- Geographical location of all the joints.
- Depth of Joint Chamber covers from ground level
- Type of chamber (Brick/Pre-cast)
- Length of O.F. Cable kept inside the joint chamber from either direction. This shall be prepared on A-4 sheets of 80 GSM.

All the diagrams (1), (2) & (3) shall bear the signatures of the bidder, the ITIL/BSNL as a proof of accuracy of the details. The diagrams shall be bound in A-4 size book with cover.

The cover sheets shall be of 110 GSM and laminated. The front cover shall have the following details.

- Name of the State/District/Block
- Name of the Panchayats connected
- Name of the ITIL/BSNL with logo
- Name of the bidder
- Date of commencement of work

- Date of completion of work

For each Block 1 sets of above-mentioned document shall be submitted to ITIL/BSNL.

## **SAFETY PRECAUTIONS**

### **Safety Precautions when excavating or working in excavations close to electric cable.**

The Officer in charge (ITIL/BSNL) of the work should get full information from Electricity undertaking regarding any electric cables, which are known or suspected to exist near the proposed excavation and unless this is done, excavation should not be carried out in the section concerned. The electricity undertaking should be asked to send a representative and work should be preceded with close consultation with them.

Only wooden handled hand tools should be used until the electric cables have been completely exposed. Power Cables, not laid in conduits, are usually protected from above by a cover slab of concrete, brick, or stone. They may or may not be protected on the sides. It is safer, therefore, always to drive the point of the pick axe downwards then uncovering a cable, so that there is less chance of missing such warning slabs. No workman should be permitted to work alone where there are electric cables involved. At least one more man should be working nearby so that help can be given quickly in case of an accident. If disconnection of power could be arranged in that section, it will be better. No electric cables shall be moved or altered without the consent of the Electric Authority and they should be contacted to do the needful. If an electric cable is damaged even slightly, it should be reported to the Electric Authority and any warning bricks disturbed during excavation should be replaced while back filling the trench. Before driving a spike into the ground, the presence of other underground properties should be checked. Information on plans regarding the location of power cables need not to be assumed as wholly accurate. Full precautions should be taken in the vicinity until the power cable is uncovered. All electric cables should be regarded as being live and consequently dangerous. Any power is generally dangerous, even low voltage proving fatal in several cases.

### **Electric Shock-Action and treatment**

Free the victim from the contact as quickly as possible. He should be jerked away from the live conductors by dry timber, dry rope, or dry clothing. Care should be taken not to touch with bare hands as his body may be energized while in contact. Artificial respiration should begin immediately to restore breathing even if life appears to be extinct. Every moment of delay is serious, so, in the meanwhile, a doctor should be called for.

Safety Precautions while working in public street and along railway lines:

- Where a road or footpath is to be opened in the course of work, special care should be taken to see that proper protection is provided to prevent any accidents from occurring.
- Excavation work should be done in such a manner that it will not unduly cause inconvenience to pedestrians or occupants of buildings or obstruct road traffic.
- Suitable bridges over open trenches should be so planned that these are required for the minimum

possible time.

Where bridges are constructed to accommodate vehicular traffic and is done near or on railway property, it should be with the full consent and knowledge of the competent railway authorities.

### **Danger from falling material**

Care should be taken to see that apparatus, tools or other excavating implements or excavated materials are not left in a dangerous or insecure position so as to fall or be knocked into the trench thereby injuring any workman who may be working inside the trench.

### **Care when working in Excavations**

Jumping into a trench is dangerous. If it is deep, workmen should be encouraged to lower themselves. Workers should work at safe distance so as to avoid striking each other accidentally with tools. If the walls of the trench contain glass bits, corroded wire or sharp objects they should be removed carefully. If an obstruction is encountered, it should be carefully uncovered and protected if necessary. If an obstruction is encountered, it should be carefully uncovered and protected if necessary. Care must be taken to see that excavated material is not left in such a position that it is likely to cause any accident or obstruction to a roadway or waterway. If possible the excavated material should be put between the workmen and the traffic without encroaching too much on the road.

### **Danger of cave in**

When working in deep trenches in loose soil, timbering up/shoring the sides will prevent soil subsidence. The excavated material should be kept at sufficient distance from the edge of the trencher pit. Vehicles or heavy equipment must not be permitted to approach too close to the excavation.

When making tunneled opening, it should be ensured that the soil is compact enough to prevent cave in even under adverse conditions of traffic. Extra care should be taken while excavating near the foundations of buildings or retaining walls. In such cases, excavation should be done gradually and as far as possible in the presence of the owners of the property.

### **Protection of Excavations**

Excavations in populated areas, which are not likely to be filled up on the same day should be protected by barriers or other effective means of preventing accidents and the location of all such openings must in any event be indicated by red flags or other suitable warning signs. During the hours from dusk to dawn, adequate number of red warning lamps should be displayed. Supervisory officers should ensure that all excavations are adequately protected in this manner as serious risk and responsibility is involved. Notwithstanding adoption of the above mentioned precautions, works involving excavations should be so arranged as to keep the extent of opened ground and the time to open it to a minimum.

### **Precautions while working on roads**

The period between half an hour after sun-set and half an hour before sunrise, and any period of fog or abnormal darkness may also be considered as night for the purpose of these instructions, for the purpose of providing the warning signs.

Excavation liable to cause danger to vehicles or the public must at all times be protected with fencing of rope tied to strong uprights or bamboo poles at suitable height or by some other effective means. Any such temporary erection which is likely to cause obstructions and which is not readily visible should be marked by posts carrying red flags or boards with a red background by day and by continuously lighted lamps at night.

The flags and the lamps should be placed in conspicuous positions so as to indicate the pedestrians and drivers of vehicles the full expanse i.e. both width and length of the obstruction. The distance between lamps or between floors should not generally exceed 1.25 m along the width and 6m along length of the obstruction in non-congested areas, but 4 meters along the length in congested areas.

If the excavation is extensive, sufficient notice to give adequate warning of the danger, should be displayed consciously not less than 1.25 m above the ground and close to the excavation. Where any excavation is not clearly visible for a distance of 25m to traffic approaching from any direction or any part of the carriage way of the road in which the excavation exists, a warning notice should be placed on the kerb or edge of all such roads from which the excavation or as near the distance as is practicable but not less than 10 m from the junction of an entering or intersecting road in which the excavation exists. All warnings, in these should have a red background and should be clearly visible and legible. All warning lamps should exhibit a red light, but white lights may be used in addition to facilitate working at night. Wherever required a passage for pedestrians with footbridge should be provided. At excavations, cable drums, tools and all materials likely to offer obstructions should be properly folded round and protected. This applies to jointer's tents as well. Leads, hoses etc stretched and across the carriageway should be guarded adequately for their own protection and also that of the public.

### **Traffic Control**

The police authorities are normally responsible for the control of traffic and may require the setting up of traffic controls to reduce the inconvenience occasioned by establishment of a single line of traffic due to restriction in road width or any other form of obstruction caused by the work. As far as possible, such arrangements should be settled in advance. If there are any specific regulations imposed by the local authorities, these should be followed.

### **Work along Railway Lines**

Normally all works at Railway crossing is to be done under supervision of the railway authorities concerned, but it is to be borne in mind that use of white, red or green flags by the Departmental staff is positively forbidden to be used when working along a railway line as this practice may cause an accident through engine drivers mistaking them for railway signals. When working along double line of railway, the men should be warned to keep an sharp look both the "UP" and "DOWN" lines to avoid the possibility of an

accident when train pass or happen to cross one another near the work spot.

### **Procedure and Safety Precautions for use of explosives during blasting for trenching**

In areas where the cable trench cannot be done manually on account of boulders and rocks, it is necessary to blast the rocks by using suitable explosives. The quality of explosive to be used depends on the nature of the rocks and the kind of boulders. A few types of explosive fuses and detonators normally used for making trenches for cable works are detailed below:

- Gun powder Nitrate Mixture Gelatin
- Safety fuse Electric Detonator
- Ordinary Detonator

### **Procedure**

A detailed survey of the route is to be done to assess the length of the section where trenching is to be done with the help of blasting. A route diagram of the rocky section may be prepared indicating the length of the route where the explosives are to be used. For the purpose of obtaining license, a longer length of route should be given in the application as in many cases, after digging, rocks appear which was not initially anticipated.

Next a license will have to be obtained for use and storing of explosive in that section. If the area falls under a police commissioner, the authority for granting such license is the police commissioner of the concerned area. When the route does not fall in the jurisdiction of a police commissioner, the authority for issuing license is the District Magistrate.

The concerned ITIL/BSNL authority should be applied in prescribed form with a route map. The concerned authority will make an enquiry and issue license for using/storing explosives for cables trenching work. Such license will be valid for 15 days only. The license should be got renewed if the blasting operation needs to be extended. Once the license is granted, it is the responsibility of the holders of the license for the proper use of explosives, its transportation and storing.

### **Method of using**

The safest explosive is the Gelatin and electric detonator. Gelatin is in the form of a stick. Electric detonator is a type of fuse used for firing the explosive electrically. Holes are made at suitable intervals on rocky terrain or boulders either by air compressor or by manual chipping. The depth of the holes should be 2 to 3 ft. Fill up the holes with small quantity of sand for about 6"

First the electric detonator is to be inserted into the Gelatin and the Gelatin is to be inserted into the holes keeping the + ve and - ve wirings of electric detonators outside the holes. Again refill the holes with sand. These +ve and -ve insulated wires of detonator are then extended and finally connected to an EXPLODER kept at a distance of not less than 100 m.

Now the explosive is ready for blasting. But, before connecting wires to exploder for blasting, all necessary precautions for stopping the traffic, use of red flags, exchange of caution signals, etc. should be completed

and only then Exploder should be connected and operated.

Operation of exploder (IDL Schaffer type 350 type exploder)

The type 350 blasting machine consists of a bearing block with blasting machine system and the explosion proof light- alloy injection moulded housing. The exploder is held with the left hand. The twist handle is applied to the drive pin, clapped with the right hand turned in the clock wise direction in continuous measurements at the highest speed from the initial position until it reached to a stop. At this stage an indication lamp will glow. When the indication lamp glows, "press button switch' should be pressed. This will extend the electric current to detonator and Gelatin will be detonated. The rock will be blasted out of the trench. Number of holes can be blasted in a single stroke by connecting all such detonators in series connection and finally to the exploder. After blasting, again mazdoors are engaged on the work to clear the debris. It the result of the first blasting is not satisfactory; it should be repeated again on the same place.

### **Warning**

There may be two reasons for unsatisfactory results of the blasting Misfire of Gelatin due to leakage of current from detonator. Over loading because of overburdens.

Never pull the broken wire pieces form the holes in such cases. Attempt should not be made to re- blast the misfired Gelatin. The safest way is to make a fresh hole by its side and put fresh Gelatin in that hole and blast it.

### **Precautions**

The abstract of Explosives Rules 1983 which are relevant to our work is given below:

#### **Restriction of delivery and dispatch of explosives**

No person shall deliver or dispatch any explosives to anyone other than a person who is the holder of a license to possess the explosives or the agent of a holder of such a license duly authorized by him in writing on his behalf? OR Is entitled under these rules to possess the explosives without a license.

The explosives so delivered or dispatched shall in no case exceed the quantity, which the person to whom they are delivered or dispatched is authorized to possess with or without a license under these rules.

No person shall receive explosives from any person other than the holder of a license granted under these rules. No person shall receive from or transfer explosives to any person for a temporary storage or safe custody in a licensed premise unless prior approval is obtained from the Chief Controller.

A person holding license for possession of explosives granted under these rules shall store the explosives only in premise specified in the license.

#### **Protection from Lightening During Storing**

Every magazine shall have attached there to one or more efficient lightening conductors designed and erected in accordance with the specification laid down in Indian Standard Specifications No.2309 as

amended from time to time. The connections to various parts of earth resistance of the lightning conductor terminal on the building to the earth shall be tested at least once in every year by a qualified electrical engineer or any other competent person holding a certificate of competency in this behalf from the State Electricity Department. A certificate showing the results of such tests and the date of the last test shall be hung up in conspicuous place in the building.

#### **Precautions during thunder-storm**

When a thunder- storm appears to be imminent in the vicinity of a magazine or store house every person engaged in or around such magazine and store house shall be withdrawn to a safe distance from such magazine or store house and the magazine and store house shall be kept closed and locked until the thunder storm has ceased or the threat of it has passed.

#### **Maintenance of records**

Every person holding a license granted under these rules for possession, sale or use of explosives shall maintain records in the prescribed form and shall produce such record on demand to an Inspection Officer.

#### **Explosives not to be kept in damaged boxes**

The licensee of every magazine or store house shall ensure that, the explosives are always kept in their original outer package. In case, the outer package gets damaged so that the explosive contained therein cannot be stored or transported, such explosives shall be repacked only after the same are examined by controller of explosives.

#### **Storage of explosives in excess of the licensed quantity**

The quantity of any kind of explosives kept in any licensed magazine or store house shall not exceed the quantity entered in the license against such kind of explosives. No explosives in excess of the licensed quantity shall be stored in the magazine or store house unless a permit in this behalf is obtained from the licensing authority by a letter or telegram.

#### **Precautions to be observed at Site**

The electric power at the blasting site shall be discontinued as far as practicable before charging the explosives. No work other than that associated with the charging operations shall be carried out within 10 meters of the holes unless otherwise specified to the contrary by the licensing authority.

When charging is completed, any surplus explosive detonators and fuses shall be removed from the vicinity of the hole and stored at a distance which should prevent accidental detonation in the event of a charge detonating prematurely in any hole. The holes which have been charged with explosive shall not be left unattended till the blasting is completed. Care shall be taken to ensure that fuse or wires connected to the detonation are not damaged during the placing of stemming materials and tamping.

### **Suitable warning procedure to be maintained**

The licensee or a person appointed by the licensee to be in charge of the use of explosives at the site shall lay down a clear warning procedure consisting of warning signs and suitable signals and all persons employed in the area shall be made fully conversant with such signs and signals.

### **Precautions to be observed while firing**

The end of the safety fuse (if used in place of a detonator should be freshly cut before being lighted. The exploders shall be regularly tested and maintained in a fit condition for use in firing. An exploder shall not be used for firing a circuit above its rated capacity. The electric circuits shall be tested for continuity before firing. All persons other than the shot-firer and his assistant, if any, shall be withdrawn from the site before testing the continuity.

For the purpose of jointing, the ends of all wires and cables should have the insulation removed for a maximum length of 5 cm. and should, then be made clear and bright for a minimum length of 2.5 cm. and the ends to be joined should be twisted together so as to have a positive metal contact. Then these should be taped with insulation to avoid leakage when in contact with earth. In case of blasting with dynamite or any other high explosive, the position of all the bore holes to be drilled shall be marked in circles with white paint. These shall be inspected by the bidder's agent. Bore holes shall be of a size that the cartridge can easily pass down. After the drilling operation, the agent shall inspect the holes to ensure that drilling has been done only at the marked locations and no extra hole has been drilled. The agent shall then prepare the necessary charge separately for each bore hole. The bore holes shall be thoroughly cleaned before a cartridge is inserted. Only cylindrical wooden tamping rods shall be used for tamping. Metal rods or rods having pointed end shall never be used for tamping. One cartridge shall be placed in the bore hole and gently pressed but not rammed down. Other cartridges shall then be added as may be required to make up the necessary charge for the bore hole. The top most cartridge shall be connected to the detonator which shall in turn be connected to the safety fuses of required length. All fuses shall be cut to the length required before being inserted into the holes. Joints in fuses shall be avoided.

Where joints are unavoidable, a semi-circular niche shall be cut in one piece inserted into the niche. The two pieces shall then be wrapped together with string. All joints exposed to dampness shall be wrapped with rubber tape.

The maximum of eight bore holes shall be loaded and fired at one occasion. The charges shall be fired successively and not simultaneously. Immediately before firing, warning shall be given and the agent shall see that all persons have retired to a place of safety. The fuses of the charged holes shall be ignited in the presence of the agent, who shall see that all the fuses are properly ignited. Careful count shall be kept by the agent and other of each blast as it explodes. In case all the charged bore holes have exploded, the agent shall inspect the site soon after the blast but in case of misfire the agent shall inspect the site after half an hour and mark red crosses (X) over the holes which have not exploded. During this interval of half an hour, nobody shall approach the misfired holes. No driller shall work near such bore until either of the following operations has been done by the agent for the misfired boreholes.

The bidder's agent shall very carefully (when the tamping is a damp clay) extract the tamping with a

wooden scraper and withdraw the primer detonator.

The holes shall be cleaned for 30 cm of tamping and its direction ascertained by placing a stick in the hole. Another hole shall then be drilled 15 cm away and parallel to it. This hole shall be charged and fired. The misfired holes shall also explode along with the new one.

Before leaving the site of work, the agent of one shift shall inform the agent relieving him for the next shift, of any case of misfire and each such location shall be jointly inspected and the action to be taken in the matter shall be explained to the relieving agent. The ITIL/BSNL shall also be informed by the agent of all cases of misfire, their cause and steps taken in that connection.

### **General Precautions**

For the safety of persons red flags shall be prominently displayed around the area where blasting operations are to be carried out. All the workers at site, except those who actually ignite the fuse, shall withdraw to a safe distance of at least 200 metre from the blasting site. Audio warning by blowing whistle shall be given before igniting the fuse.

Blasting work shall be done under careful supervision and trained personnel shall be employed. Blasting shall not be done within 200 meters of an existing structure, unless specifically permitted by the ITIL/BSNL in writing.

### **Precautions against misfire**

The safety fuse shall be cut in an oblique direction with a knife. All saw dust shall be cleared from inside of the detonator. This can be done by blowing down the detonator and tapping the open end. No tools shall be inserted into the detonator for this purpose. If there is water present or if the borehole is damp, the junction of the fuse and detonator shall be made water tight by means of tough grease or any other suitable material. The detonator shall be inserted into the cartridge so that about one-third of the copper tube is left exposed outside the explosive. The safety fuse just above the detonator shall be securely tied in position in the cartridge. Water proof fuse only shall be used in the damp borehole or when water is present in the borehole. If a misfire has been found to be due to defective fuse, detonator or dynamite, the entire consignment from which the fuse, detonator or dynamite was taken shall be got inspected by the ITIL/BSNL or his authorized representative before resuming the blasting or returning the consignment.

### **Precaution against stray currents**

Where electrically operated equipment is used in locations having conductive ground or continuous metal objects, tests shall be made for stray current to ensure that electrical firing can proceed safely.

### **Horizontal Directional Drilling (HDD)**

**HDD Overview:** Horizontal directional drilling is an excellent alternative to traditional utility installation methods. Unlike manual labor, trenching or excavation, the HDD process is highly suitable in urban areas

or places where aboveground obstructions exist that are expensive, inconvenient or impossible to disturb for product installation. HDD machines install utilities under obstacles such as roads, rivers, creeks, buildings and highways — with little or no impact to the aboveground surface.

**Drill Rig:** Horizontal directional drilling machines are available in many sizes. Regardless of a machine's size, it has three main functions — rotation, forward thrust/pullback and fluid flow.

**HDD Process:** Horizontal directional drilling machines will bore under or around obstacles. Once the drill path is planned, an underground pilot bore is performed utilizing a series of drill rods connected to a drill head. After the pilot bore is completed, a back reamer is attached to the drill string that enlarges the drill path to accommodate the product that will subsequently be pulled into place. Vermeer NAVIGATOR horizontal directional drilling machines can install product under roads, buildings, railroad tracks, streets, rivers, creeks and in congested underground areas.

**Steering:** Steering refers to control of the direction of a drill path. The shape of a drill bit on the drill head allows an operator to change the drill path direction during a bore. When an operator points the drill bit downward to the 6 o'clock position and pushes the drill head forward, the drill head goes deeper. When the drill faces the 12 o'clock position, the drill head will rise. Pushed to the 9 o'clock position, the head goes left. Pushed to the 3 o'clock position, the head goes right. If no change in drill path is needed, the drill head and rod are rotated while thrusting.

**Locating:** Prior to starting a bore, the drill head is equipped with a transmitter that sends signals to an aboveground receiver during the bore. The drill head's location must be tracked during a bore in order to provide steering position information to the HDD operator.

## **ALLIED ACTIVITIES**

**Storing/Warehousing of Materials:** Bidder will be responsible for storing and warehousing of all the material and accessories, but not limited to, supplied by him at his own cost if warehouse not provided by ITIL/BSNL.

**Transportation of Materials:** The bidder shall be responsible for transporting the materials, to be supplied by the ITIL/BSNL or otherwise to execute the work under the contract, to site at his/ their own cost. The costs of transportation are subsumed in the standard quoted Rates and therefore no separate charges are payable on this account.

**Disposal of Empty Cable Drums:** The bidder shall be responsible to dispose of the empty cable drums after laying of the cables. The cost of various sizes of empty cable drums recoverable from the bidder will be fixed taking into account the prevailing market rates.

It shall be obligatory on part of the bidder to dispose of the empty cable drums at his/their level and the amount fixed for various empty cable drums shall be recovered from the bill for the work for which the

drum (s) was/were issued or from any other amount due to the bidder or the Security Deposit. The bidder shall not be allowed to dump the empty cable drums in Govt. /Public place which may cause inconvenience to the ITIL/BSNL / public. If the bidder does not dispose of the empty cable drums within 3 days of becoming it empty, the ITIL/BSNL shall be at liberty to dispose-off the drums in any manner deemed fit and also recover the amount fixed in this contract from the bill/security deposit/ any other amount due to the bidder.

**Supply of Materials:** There are some materials (Accessories) other than as mention in BoQ required to be supplied by the bidder for execution of work under this contract like Bricks, Cement, Wire Mesh and Steel for protection, etc., besides using other consumables which do/don't become the part of the asset. The bidder shall ensure that the materials supplied are of best quality and workmanship and shall be strictly in an accordance with the specifications.

**Social auditing:** While carrying out the execution work of cable/Eqpt., videography may be carried out on sample basis for duration of 15 to 30 minutes per Gram Panchayat which may also involve the local people of the Gram Panchayats and villages including the Gram Panchayat Pradhan (If possible) and same may be submitted in a form of CD along with the documentation sets for information.

**Note:** All the materials as above have to be TSEC/Type approved by BSNL/QA/TEC against mentioned TEC GR or as per the approval procedure of ITIL/BSNL for which TEC GR not there.

**Figure 1**

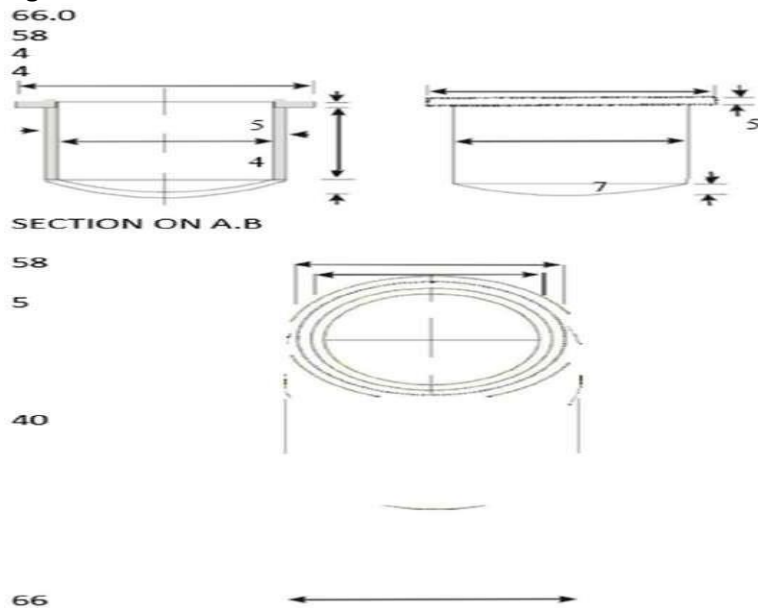

**Figure 2**

M.S. WELDMESH

DETAILS OF 100 MM X 50 MM, 12 SWG MILD STEEL WELD MESH HAVING WIDTH OF

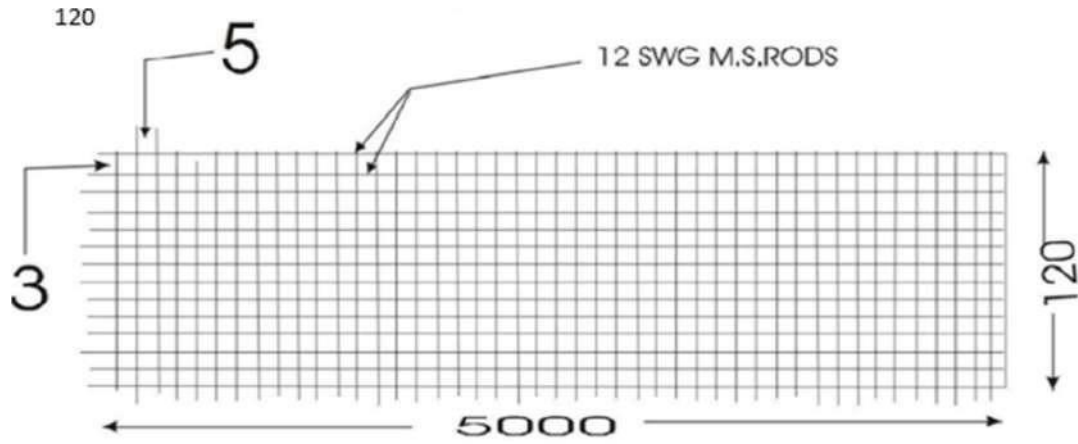

**Figure 3**

Rubber Cork

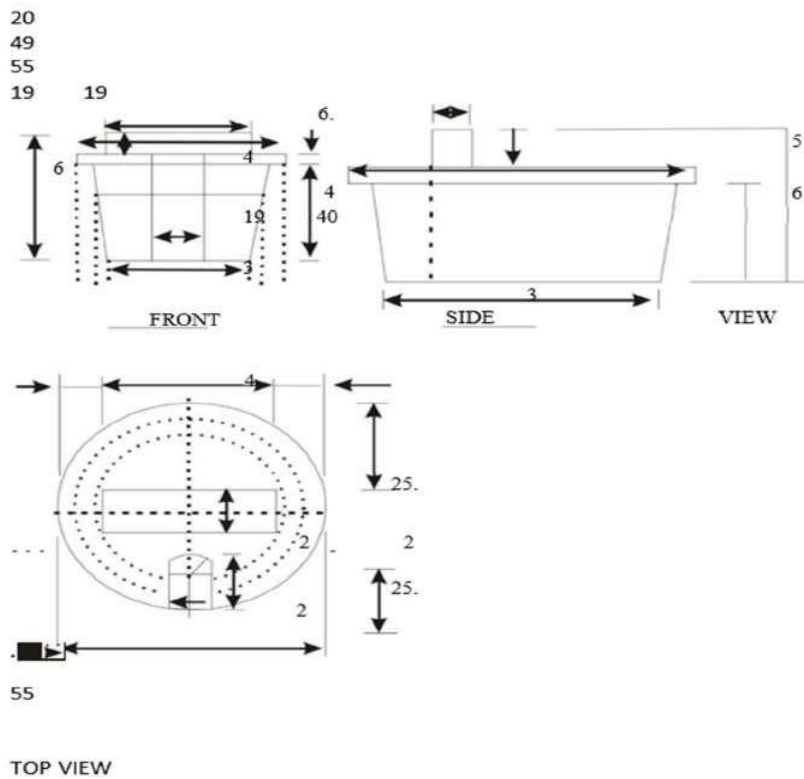

Note:

- All dimensions are in mm.
- Dimensions are only for guidance. Tapper should be such that it should tightly fix into type A and type B hope 50 mm OO pipes

Figure 5

RCC Router Indicator

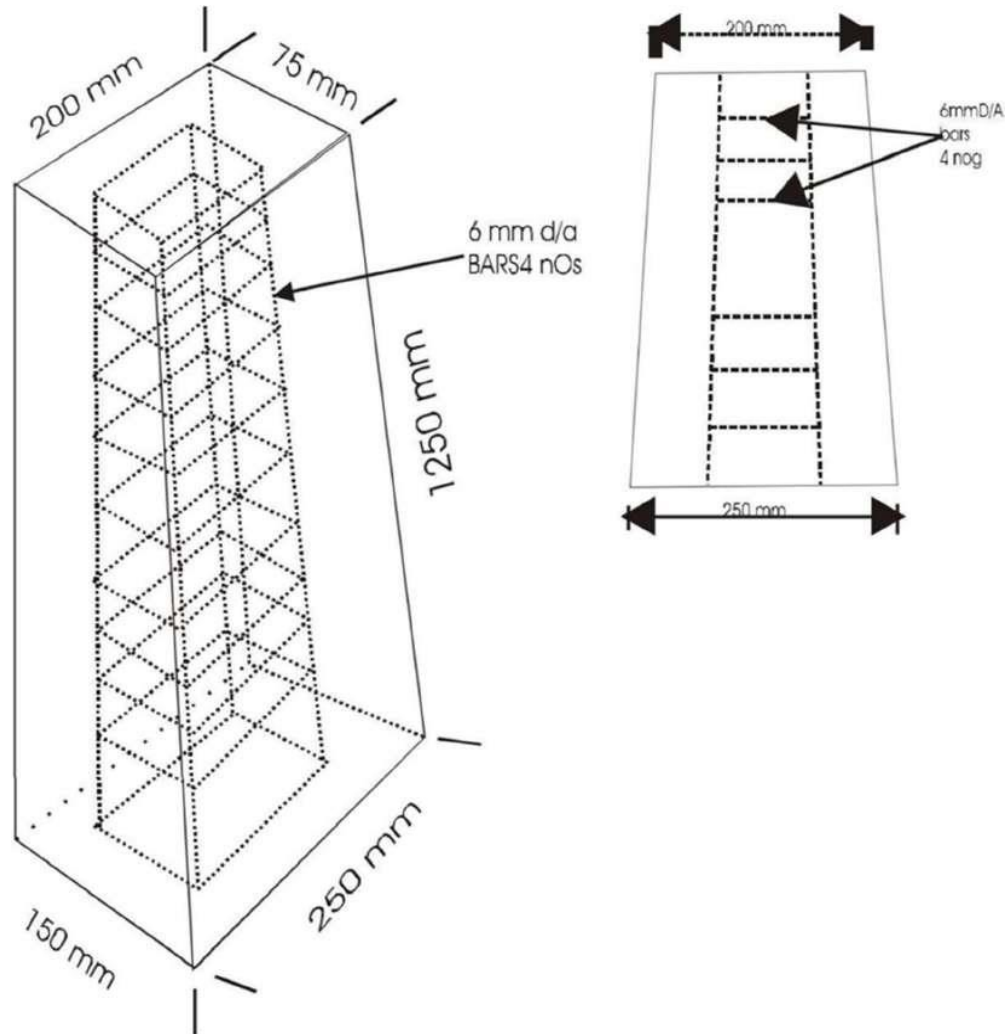
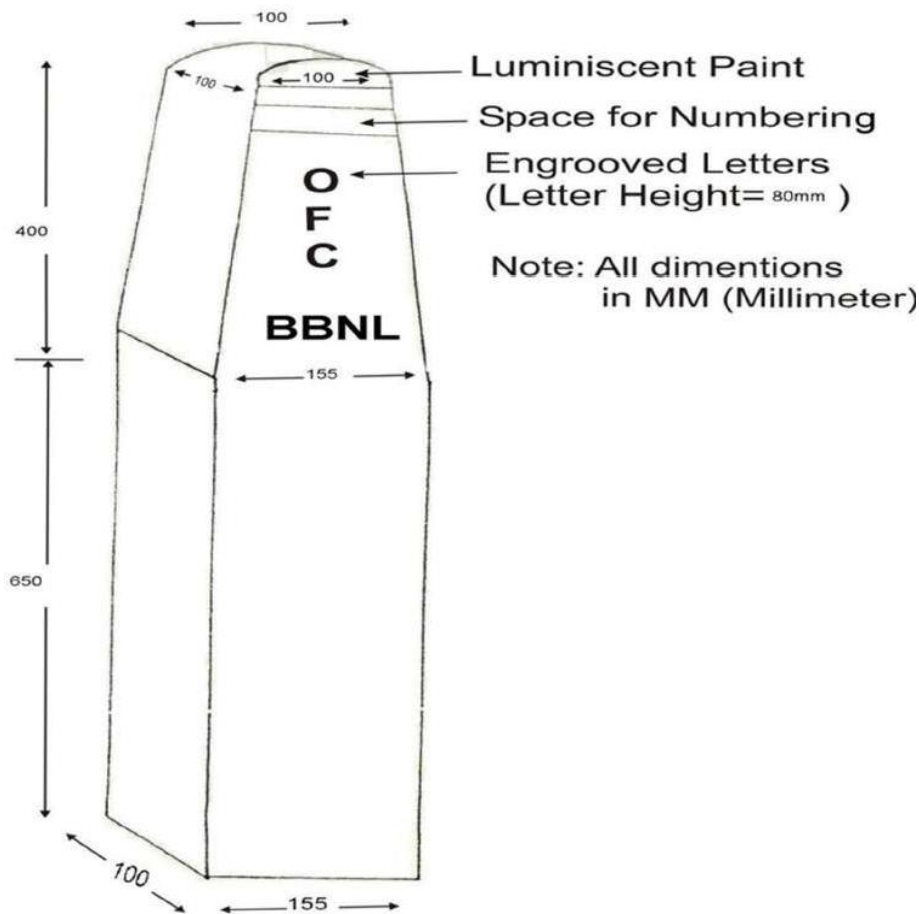

Figure 6

## 1. Stone OFC Route Indicator



### Penalty for Deviation from Standard Engineering Instructions Underground Laying

- Normally depth of the trench should be 1.65 m in normal & mix soil and 1.2m in hard soil. Deviations due to field conditions will be required to have necessary protections in case of less depth. The cases and solutions are as following;
- Minimum depth of burial in general shall be 1.65m
- In rocky/ hilly area (including Murrum & soil mixed with stone or soft rock) depth of burial shall be 1.2m at the minimum.
- In case of utility where depth is 100 to 120 cm then DWC protection is to be used in normal/mix soil case.
- In some areas where the depth is 60cm, in those cases reinforced concrete casing of 4"(Four inch) round or GI pipe should be provided.
- For hard strata/rock soil layer for 50 to 80 cm cases DWC with wire mess and PCC or GI pipe is to be used. However, for depth relaxation photograph (with GPS) proof and justification is required.

- Above ground installation of ducts shall be limited to culvert and bridge crossings only. At such locations, ducts shall be installed inside GI pipe or HDPE DWC pipes with metal sheet protection (GI sheet wrapping) of appropriate size (4" to 6") suitable for number of ducts to be installed.
- Trenching depth under no circumstances shall be less than 30cms. Trenching work in soft/hard rock patches are to be achieved using rock breakers or any other method deemed fit.
- The relaxation by the competent authority prescribed below shall be obtained giving reasons for not achieving standard depth;

**Note:**

In case of rocky/hilly soil, full payment is to be made for depth equal to or more than 1.2 m. The details of payment to be made in less depth cases are mentioned at “**Rates payable in case of laying at less depth**” of tender document.

Duct: Extra 2% of trench length to account for actual PLB length in trenches. The payment shall be made with above factor included.

In compliance, joint chambers are to be provided at every joint to keep the O.F.C. joint well protected and also to keep extra length of cable, which may be, required to attend the faults at a later date. Separate payment shall be made for construction of Joint Chambers. Extra OFC length shall normally be kept @ 20 meter per joint. However, to avoid wastage of OFC, extra length beyond 20 meters and up to 100 meters may be allowed.

The payment of OFC shall be made as per the end-to-end rodometer length.

\*\*\*\*\*

## **C2- INSTALLATION PRACTICE OF SELF-SUPPORTING METAL FREE AERIAL OPTICAL FIBRE CABLE**

### **1. Introduction**

This engineering Instruction (EI) deals with the guidelines and the installation practice for installing of self- supporting metal free aerial optical fibre cable.

### **2. General Guidelines**

#### **2.1 General Instruction for *Installation of ADSS:***

- a. The methods described in this Engineering Instruction for installation of All Dielectric Self-Supporting (ADSS) fiber optic cable are intended to be used as guidelines by design engineers and outside plant construction personnel. This guide is generic enough, and yet contains sufficient specific information, to be applicable for most installations of ADSS cable, however, local conditions, existing engineering and customer procedures and requirements must be considered.
- b. ADSS Cables should meet National Electric Safety Code (NESC) loading requirements for heavy, medium, and light loading conditions in their sag/tension tables. Special tables can be generated based on specific customer installation requirements, which may include minimum separation and clearance, sag requirements, and loading conditions.

- c. It is assumed that the personnel using the information presented in this document have prior experience in the planning, engineering or placement of ADSS fiber Optic Cable.
- d. The ADSS Cable should meet the P1222 IEEE Standard for All- Dielectric Self- Supporting Fiber Optic Cable (ADSS).

## **2.2 Precautions during Installation of ADSS:**

The following are some suggested precautions which should be observed when working with fiber optic cables. Before starting any aerial fiber optic cable installation, all personnel must be

- a. Thoroughly familiar with Occupational Safety and Health Act (OSHA) regulations. Each individual company's safety precautions for ADSS fiber optic cable installations should be reviewed before work begins and practiced during the entire installation process.
- b. Before cable installation begins, the cable reels should be carefully inspected for any imperfections such as nails and broken flanges which might cause damage to the cable as it is laid out. Precautions should be taken to protect stored reels from possible damage by vandals or other sources when left unattended.
- c. Fiber optic cable is a high capacity transmission medium which can have its transmission characteristics degraded when subjected to excessive pulling force, sharp bends, and crushing forces. These losses may not be immediately revealed after installation. For these reasons extra care must be taken during the entire installation process.
- d. Whenever cable from the reel is placed on pavement or other surfaces, it should be protected with barricades or cones to prevent possible vehicular or pedestrian traffic damage.
- e. Fiber optic cables are susceptible to performance degradation due to tight bending. The minimum bend radius of each cable is specified relative to the cable's diameter. During installation a cable not be exposed to a bend radius smaller than 20 times the cable diameter and that after installation a cable should not be exposed to a bend radius smaller than 10 times the cable diameter.
- f. Whenever cable from the reel is placed on pavement or other surfaces, it should be protected with barricades or cones to prevent possible vehicular or pedestrian traffic damage. A "figure-eight" configuration should be used when the cable is removed from the reel and piled on the ground. This prevents kinking and twisting of the cable which could cause damage. Fiber optic cable should not be coiled in a continuous direction except for lengths of 30 meters (100 ft) or less. The preferred sized for the "figure-eight" is about 4.5 meters (15 ft) in length with each loop 1.5 meters (5 ft) to 2.4 meters (8 ft) in diameter.

**Note:** An alternative to the manual figure-eight is the "figure-eight" machine. This equipment will "figure-eight" cable much faster than manual methods saving time and manpower. Using a "figure

eight” machine the remaining cable on the reel is wound on the machine’s drum. Once the inside cable end is accessible, the machine is reversed and the cable is pulled from the machine through the duct. The machine’s drum and rollers are designed to keep the cable at a bend radius that exceeds the minimum bend radius of the cable.

- g. Never, during the pull-in process, should the fiber optic cable experience sags, bends or twists that produce in the cable a bend whose radius is smaller than that specified as the minimum bend radius for the cable being installed.
- h. Do not cut the Cable under any circumstances without prior approval of the engineer responsible for the project. Splice locations are determined in the initial system design by the project engineer. Introducing new splices can potentially degrade the transmission characteristics of the system.
- i. Temporary or permanent guys should be installed at any location where the self- supporting cable is tensioned to avoid placing an unbalanced load on the support poles. Wire mesh grips are intended for pulling the cable into place and are not intended for tensioning the cable in place. Do not use split wire mesh grips to tension or to hold cable under tension.

### **2.3 Accessories and tools for Installation of ADSS:**

- a. The type and construction of the reel support determines the method and tools for handling. Reel construction requires that they be mounted on an axle or be supported by the reel flange. The equipment used must be rated for the maximum load and be able to lift the reel. When the reel stand is not self-loading, a crane, forklift or some other method of lifting must be available to lift the reel onto its stand.
- b. The reel support design employed must incorporate an adjustable brake to supply the necessary hold-back tension needed to properly tension the cable. The cable may be pulled directly from the reel support when employing slack stringing methods that apply minimal tension to the reel of cable.
- c. Capstan and reel type pulling machines with approved adjustable tensioners may be used to install the ADSS fiber optic cable.
- d. The pulling and braking system employed should operate smoothly to prevent any jerking or bouncing of the cable during placement. The system should be controllable and able to maintain a constant and even tension on the cable during the installation process. Pullers and tensioner should be equipped with tension indicator and limiting devices. Tensioner wheels should be controlled so that a constant hold-back tension is maintained at all pulling speeds. A braking system to maintain cable tension when pulling is stopped is required.
- e. Sheave diameters larger than those specified in Paragraph 2.5 are suggested, especially at the payoff reel position and the take-up or winch location. A larger diameter than the minimum diameter

required offers the advantage of reducing the load applied to the cable.

- f. The depth and flare of grooves in wheels used during the placing process are not critical, but there are some recommended guidelines that should be followed. The sheave grooves should have depth of 25% greater than the cable diameter with a flare angle of 15 to 20 degrees from vertical. This will facilitate the passage of grips, swivels, etc. and contain the cable within the groove. The material and finish of the grooves should be such that it does not mar the surface of the cable.
- g. Traveler, sheave, or quadrant blocks used should be in good working order and properly lubricated. The cable release should work smoothly with minimal pressure. These should be lined so that they do not cause any abrasion of the cable jacket. A plastic lining of neoprene or urethane are acceptable.
- h. Tangent supports made of metal with a protective pad can be used as a replacement for stringing blocks. These supports are mounted directly on the pole and open from the top. The protective pads can be removed and the top closed and secured for stringing.
- i. At places where uplift may occur, it is recommended that uplift rollers or hold down blocks be used.
- j. Wire mesh grips or pulling eyes can be used to pull the cable into place through the travelers, sheaves, or quadrant blocks. The mesh grip or pulling eye must be used in conjunction with a swivel link which will minimize cable twisting that can be introduced by the pull rope. The load rating of the swivel link shall not exceed the maximum pulling tension rating of the cable.

## 2.4 ADSS Installation Methods

There are two primary method used for placing ADSS cable. Both these methods are very similar to those methods used to place most aerial cables. The first method is called the stationary reel, or the "Pull-back Method," and the second is called the moving reel, or the "Drive-out Method."

**The Pull-back Method:** The Pull-back Method is illustrated in **Figure A** below.

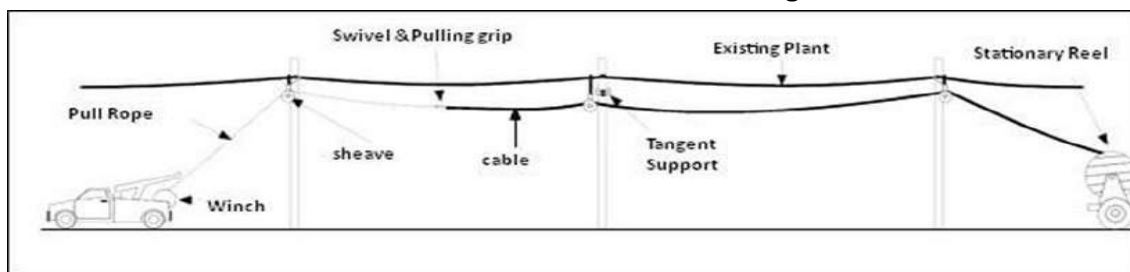
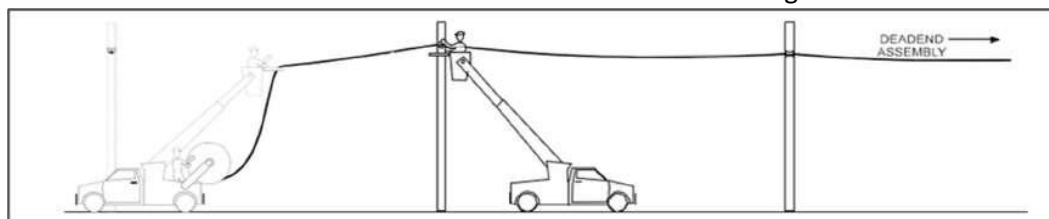

*Figure A: The Pull-back Method of Installation of ADSS*

- a. Holes are drilled in all poles along the cable run and line pole hardware is attached to the poles at the engineered height. At dead-end and tangent locations, down guys are placed at the correct position according to local engineering practices.

- b. Travelers, sheaves, or quadrant block are placed just above or just below the location of the installed pole line hardware at each pole location. The diameter of these supports must meet the minimum bend radius specs for the cable in any location where the cable will be bent more than 20 degrees. The cable warranty is void if these limits are not observed.
- c. Please note that if tension is let off the cable during a pull, the natural sag of the cable will usually produce angles larger than 20 degrees at each support point. Thus, extreme caution must be used if pulling through small diameter supports.
- d. The pulling line is then pulled through each traveler, sheave, or quadrant block. After the pulling line is in place, it is attached to the ADSS cable with a break-away swivel and a factory installed pulling eye. A wire mesh grip may be used when a pulling eye has not been installed.
- e. The ADSS cable is then pulled in through the entire section using the puller and the tensioner. Care must be taken to avoid over tensioning the cable and to avoid sagging of the cable that may introduce bends that are smaller than the minimum bending radius of the cable. Several pulling stages may be required to place the cable through the entire system.
- f. When the entire cable has been pulled into place, starting at an end location, each dead-end to dead-end cable length can be sagged and tensioned and support hardware applied according to the installation requirements.

The **Drive-back Method**: The Pull-back Method is illustrated in Figure B below:



*Figure B: The Pull-back Method of Installation of ADSS*

- a. The Drive-out method of cable placement is primarily used during the construction of new lines where there is a clear right-of-way and with no obstructions to vehicles.
- b. The reel of cable is placed on a reel trailer or a truck equipped with a reel carrier. The cable should play off the top of the reel for reel trailers and the bottom of the reel for trucks equipped with a reel carrier. The reel trailer or reel equipped truck should have a braking device, set on minimum. The brake is used to prevent overrun of the reel when stopping at the support poles.
- c. Holes will have to be drilled at the poles to mount the support hardware. At dead-end and tensioning locations, down-guys of the correct loading factor are to be placed according to local engineering practices

- d. Travelers, sheaves, or quadrant blocks are placed above or below the pole mounting hardware at each pole location.
- e. With the cable dead ended at the starting location and minimum tension applied to the reel brake, the reel of cable is transported along the construction route while the cable is played out.
- f. As the reel passes a pole location, the trailer or truck must be stopped while the cable is placed into the traveler, sheave, or quadrant block attached to the pole.
- g. The reel then travels on to the next pole where the process is repeated over again. This continues until the cable is completely deployed or a dead end is reached.
- h. With the cable deployed, each span must be sagged and tensioned with supporting hardware installed. Each span is started at the dead end and slack worked back towards the opposite end. An alternative method is to sag and tension each span and install permanent hardware as the cable is being deployed.

## **2.5 Route Survey**

The route should be inspected before the actual installation of optical fibre cables. Survey of the aerial route should be carried out pole by pole.

## **2.6 Over Head Alignment**

The existing route alignment wherever available should be used. On new routes, alignment should be erected. The span length must not exceed above 90 metres.

## **2.7 Line Diagram**

- a. A line diagram should be prepared to mark the poles & the actual distance between the poles in a splice section (Normally 15 poles per km are recommended).
- b. Additional poles should be erected if required to keep the span length within the specified limits.
- c. Care should be taken that the alignment is easily accessible from the road. It is necessary to keep a clear head way (Ground clearance) of 12 to 15 feet in a section.
- d. A complete line diagram should be prepared i.e. from station A to station B.
- e. The number of road crossings, canals or nallahs, electric lines should be clearly marked in the route diagram.

## **2.8 Hilly Regions**

- a. Line erection rules must be strictly followed. Additional poles may be erected for better support to optical fibre cable & to avoid sharp curves & bends.
- b. Span lengths should be reduced to avoid sags in case of steep slopes.

## **3. Installation of ADSS on New poles**

### 3.1 Tension Poles

Tension poles are dead end or termination poles. The tension poles shall have dead end fittings. The dead end fittings offer a continuous run of the aerial optical fibre cable. These fittings relieve the optical fibre cable of its compressive, bending & clamping stresses. The performed dead end fittings are suitably gritted for excellent tensile holding strength.

#### 3.1.1 Selection of Tension Poles

Selection of tension poles depends upon the actual site location of the route. Every fifth pole should be a tension pole in straight alignment. Splicing location poles should be tension poles or wherever alignment takes a sharp turn (more than 15 degrees) should also be a tension pole.

### 3.2 Suspension Poles

The suspension pole assembly is designed to offer cushion to aerial optical fibre cable against the dynamic stress of Aeolian vibration at the suspension point. They also reduce static stresses at the Support point.

### 3.3 Selection of Poles

Selection of suspension poles also depends upon actual site location of route. All the intermediate poles between two tension poles will be suspension poles.

#### 3.3.1 Selection of Splice location

The splice box of the aerial optical cable should be buried underground. Therefore it is necessary to fix & determine the splicing location as per the designated cable drum length.

#### 3.3.2 Aerial optical Fibre Cable Specifications

Sl. No.	Description	Specification
1.	Maximum span length	90 metres
2.	Maximum ice loading	1 Kg per meter
3.	Operational wind velocity	75Kms per hour
4.	Maximum sag allowed (without excess load)	2% of span length
5.	Maximum sag allowed (with excess load)	3% of span length
6.	Temperature range	
6.1	operation & storage	-30 to +70 degree C
6.2	installation	-15 to +50 degree C
7.	Minimum bend radius	2D (D-Dia of cable)
8.	Tensile force	
8.1	During installation	$9.81 \times 1.3 \times \mathbf{w}$
8.2	Permanent with ice & wind load	$9.81 \times 3 \times \mathbf{w}$ (where $\mathbf{w}$ is the mass of 1 km length of cable, in kg)

### **3.4 Type of Accessories and Fixtures**

#### **3.4.1 Formed OFC Dead End and Termination Fittings**

These fittings are used at tension/termination poles (dead end poles), or poles where splices are located and the poles where the overhead alignment takes a turn, (angle exceeding more than 15 degrees) as shown in fig. 1.

##### **a. J-SHAPED TENSION HOOK**

J - Shaped tension hook is for the installation on cross arm channel C (C-Bracket) of the poles as shown in fig. 2.

##### **b. TURN BUCKLE**

Galvanized forged steel turn - buckle is used at the dead end and at tension positions (for adjusting the sag & tension) as shown in fig. 3.

##### **c. EXTENSION LINK**

Galvanized steel extension link is used along with turn buckle as shown in fig. 4.

##### **d. CLEVIS THIMBLE**

Aluminum alloy die cast thimble is used to attach the extension link and for accommodating the loop of the helically formed terminating helix at the other and its smooth internal contour as shown in fig.5.

##### **e. PROTECTIVE HELIX (T)**

Set of aluminum alloy helically formed protective helix having predetermined spiral shape is used & making them conveniently applied on the optical fibre cable without excessive clamping pressure at any point. See fig.

##### **f. TERMINATING HELIX**

Helically formed terminating helix of Aluminized steel having a prefabricated loop shall be to fit into the grooved contour of the thimble and for fixing over protective helix over the optical fibre cable. See fig. 7.

##### **g. JUMPER CABLE CLAMP**

Galvanized steel jumper cable clamp is used to support the through length of optical fibre cable at the intermediate tension poles as shown in fig. 8.

##### **h. POLE MOUNTED STAY CLAMP (TUBULAR) OR POLE MOUNTED STAY CLAMP (RAIL)**

Galvanized mild steel pole mounted stay clamp should be used at the pole for the fixing with a twisted eye & turn buckle; see figs. 9 & 10.

The selection of the type of stay clamp will depend upon the type of poles.

### 3.4.2 OFC SUSPENSION FITTINGS

Helically formed suspension fittings along with the elastomeric pads inserts strapped by a galvanized steel eye-band is used to hang from the twisted eye-link connected to a pole mounted stay clamp or on the tension hook (J-shaped) installed on the C bracket at the intermediate poles as shown in fig. 11.

#### a. TWISTED EYE LINK

The twisted eye link is used for installing suspension fitting on stay clamp or on tension hook as shown in fig. 12.

#### b. PROTECTIVE HELIX (S)

Set of aluminum alloy helically formed protective helix having predetermined spiral shape is used & making them conveniently applied on the optical fibre cable without excessive clamping pressure at any point. See fig. 13.

#### c. ARMOUR GRIP HELIX

Set of aluminum alloy armour grip helix is used or fixing on the profile shaped elastomer pad for proper strut action, grip & bird caging as shown in fig, 14.

#### d. SUSPENSION CLIPPER WITH ELASTOMER PAD

Set of suspension clipper (made of aluminum alloy permanent mould die cast split type clamp) is used to support the elastomer pad inserts & is strapped by a galvanized steel eye-band in order to hang from a twisted eye-link connected to a pole mounted stay clamp or tension hook as shown in fig. 14.

#### e. SPIRAL VIBRATION DAMPER (SVD)

Helically formed spiral vibration dampers are used on both sides of suspension fittings as shown in fig. 1

### 3.4.3 DEMOUNTABLE PULLEY

Demountable pulleys are used during the installation of aerial optical fibre cables see fig.16.

These are made from mild steel & the contour of the wheel is coated with rubber or any other suitable material for free movement of cable.

### 3.4.4 Material requirement of installation accessories and fixtures

#### a. FOR DOUBLE TENSION POLES

Sl. No.	Description	Quantity
1.	J-shaped tension hook (For C-bracket)	2
2.	Turn buckle	2

3.	Extension link	2
4.	Clevis thimble	2
5.	Protective helix (T)	2 Set
6.	Terminating helix	2 Set
7.	Jumper cable clamp	
a.	Pole mounted stay clamp(Tubular)	1 (Pole having C-bracket)
	Pole mounted stay clamp (Tubular)	2(Pole without C- bracket)
	OR	
a.	Pole mounted stay clamp (Rail)	1(Pole having C- bracket)
b.	Pole mounted stay clamp (Rail)	2(pole having C-bracket)

**b. FOR SUSPENSION (INTERMEDIATE POLES)**

Sl. No.	Description	Quantity
a	Pole mounted stay clamp (Tubular)	7
b	Pole mounted stay clamp (Tubular)	
	(Or)	
a	Pole mounted stay clamp (Rail)	
b	Pole mounted stay clamp (Rail)	
c	Twisted eye link	1 Set
d	Suspension Clamp consisting of the following:	
i	Protective Helix (S)	1 Set
ii	Armour grip helix	
iii	suspension clipper with elastomer pad etc.	1 Set
iv	viral vibration damper shaped tension hook	1 (Pole with C-bracket)
v	mountable pulley	One per pole in the splice section

**“Note:** The ADSS accessories to be used shall be Helix Type-I as per GR.no. 87060: 2017. The type of pole clamp to be used shall depend on type of poles and optical fiber cable used in the network; to ascertain the required SLA”

**3.4.5 ENTRY OF THE O.F. CABLE IN THE BUILDING**

Normal methods for leading in and precautions recommended for leading-in of the optical fibre cable should be followed. A conduit pipe should be laid for leading-in the O.F. cable inside the building; the cable may also be taken directly from the nearby O/H pole to inside of the building for termination.

- a. Before the installation the O.F. cable should be tested.
- b. As per requirement install the additional new poles.
- c. Each pole should be checked for its strength. Provide extra stays if more strength is required.
- d. The Aerial O.F. Cable is recommended to be installed on the outermost hole of bracket towards

- road on the existing bracket/new bracket on the poles.
- e. Replace weak and other poles for clear ground clearance and strength as per the field conditions.
  - f. Provide ground clearance of 12 feet in non-obstructing areas.
  - g. Raise the height to minimum 16 feet at all the road crossings.
  - h. Maintain the alignment as straight as possible.
  - i. Construct splice chambers

### 3.5 SPLICE LOCATIONS

The field splices should be buried underground. The cable should be brought down through a 40mm dia GI pipe clamped on the pole. Proper bends (120-135 degree) are recommended for negotiating the bend. Wooden/hard rubber bushes shall be used at the entry and exit points of the GI pipe to avoid damage to the cable.

A splice chamber as per the standard practice shall be made. The selection of the splice point shall depend upon the availability of space and the cable length.

Wherever, burying of splice closure is not possible, the same be installed on the poles with proper clamping with the approval of ITIL/BSNL.

### 3.6 CALCULATION OF SECTION LENGTH

Aerial O.F. cable is supplied as per TEC GR in a length of 2 Kms  $\pm$  10%.

To arrive at the section length and allocating a particular reel of the cable to a particular section following consideration are required.

Strength Length

- Actual section length measured
- Allowance for sag 2% for each span length
- Cable at each through tension pole (4 meters)
- Extra spare cable for coiling at the splice location (10 meters)

### 3.7 INSTALLATION MATERIAL REQUIRED DURING INSTALLATION

Sl. No.	Description	Quantity
1.	Demountable pulleys	1 each for each pole in the installation section
2.	Jack for cable drum	1 set
3.	Ladders	For each pole
4.	Tools	Screw drivers C&T pliers Spanner set & hammer etc.
5.	Manila rope 12 mm dia	250 meters
6.	Cable pulling winch machine with tension monitoring device	1
7.	Anti twist device	1
8.	Cable pole fork	10
9.	Flat twin open type cable grip	2

### 3.8 INSTALLATION OF AERIAL OPTICAL FIBRE CABLE

The following steps are recommended:

- a. Install the accessories and fixtures as per the requirement of the individual poles its tension and suspension fittings.
- b. Install the demountable pulley on all the poles in the section before pulling the cable.
- c. Keep the cable drum over the jack near the 1st pole at the beginning of the section.
- d. Attach anti twist device and the shackle hook along with the rope to the front end of the cable on pulling eye or on the cable grip. Carry the attached rope over the demountable pulleys for pulling the cable.
- e. Depute one person at each pole to monitor and in case it is required to guide the cable over the demountable pulley during pulling operation.
- f. The cable should be pulled till the cable reaches the last pole of the section.
- g. Wherever in the pulling section; through pulling is difficult; half section or one fourth, action pulling method may be adopted by using figure of a techniques.
- h. The feeding and pulling of the cable should be synchronized by using communication link. Care is required to be taken so that the cable is not accumulated at any one point during pulling operation and sharp bends are avoided.
- i. Once the cable reaches the other end actual tensioning of the cable and fixing the installation of the accessories and fixtures shall be taken up with the help of cable pulling winch. The pulling tension must be monitored during tensioning
- j. Install the tension fittings and accessories at the 1st pole.
- k. Fix a flat twin open type cable grip on the cable after tension pole for tensioning the cable in the preceding tension section.
- l. The cable shall be tensioned to a tension of 1-3 to 1-6 times of the cable weight. The sag shall be monitored and kept between 0.25 to 0.5% of the span length.
- m. The cable should be lifted between two poles by using cable pole fork during tensioning and fixing of the cable
- n. During the fixing operation the cable shall remain under required tension for minimizing the sag in the splice section.
- o. Now install tension fitting and accessories at the all tensioned pole at the end of the tension section.
- p. Install the suspension fitting and accessories on the intermediate poles in the tensioned section
- q. Similarly, installation should be carried out in each tension pole in the entire section and the tension and suspension fittings are installed.
- r. At the Through tension poles the cable shall be kept loose and shall be supported by cable jumper clamp.
- s. At the end pole where the cable reel is kept; the cable to be taken through GI pipe (fixed to the pole) to the splice location.
- t. Extra care for the aerial O.F. cable may be taken at the bends and at entry and at the exit of the

pipe. About 10 meters of cable shall be kept at the splice location for coiling (spare cable) and jointing requirement.

- u. Test the installed OF cable.
- v. Coil the OF cable and keep it safe in the splice location for splicing.

### **3.9 PRECAUTIONS**

- a. Provide display boards
- b. Provide sufficient number of road sign and traffic cones.
- c. Avoid sharp bending of the OF cable during installation.
- d. The OF cable should not be given extra tension than the permissible tension limits
- e. While crossing the overhead electric installations, safety measures should be taken. Also provide guard wire.
- f. To avoid man made damages, safety measures should be taken for each pole

### **3.10 REFERENCE**

TEC GR on Planning Guidelines and the Installation Practices for the installation of self-supporting metal free aerial optical fiber cable.

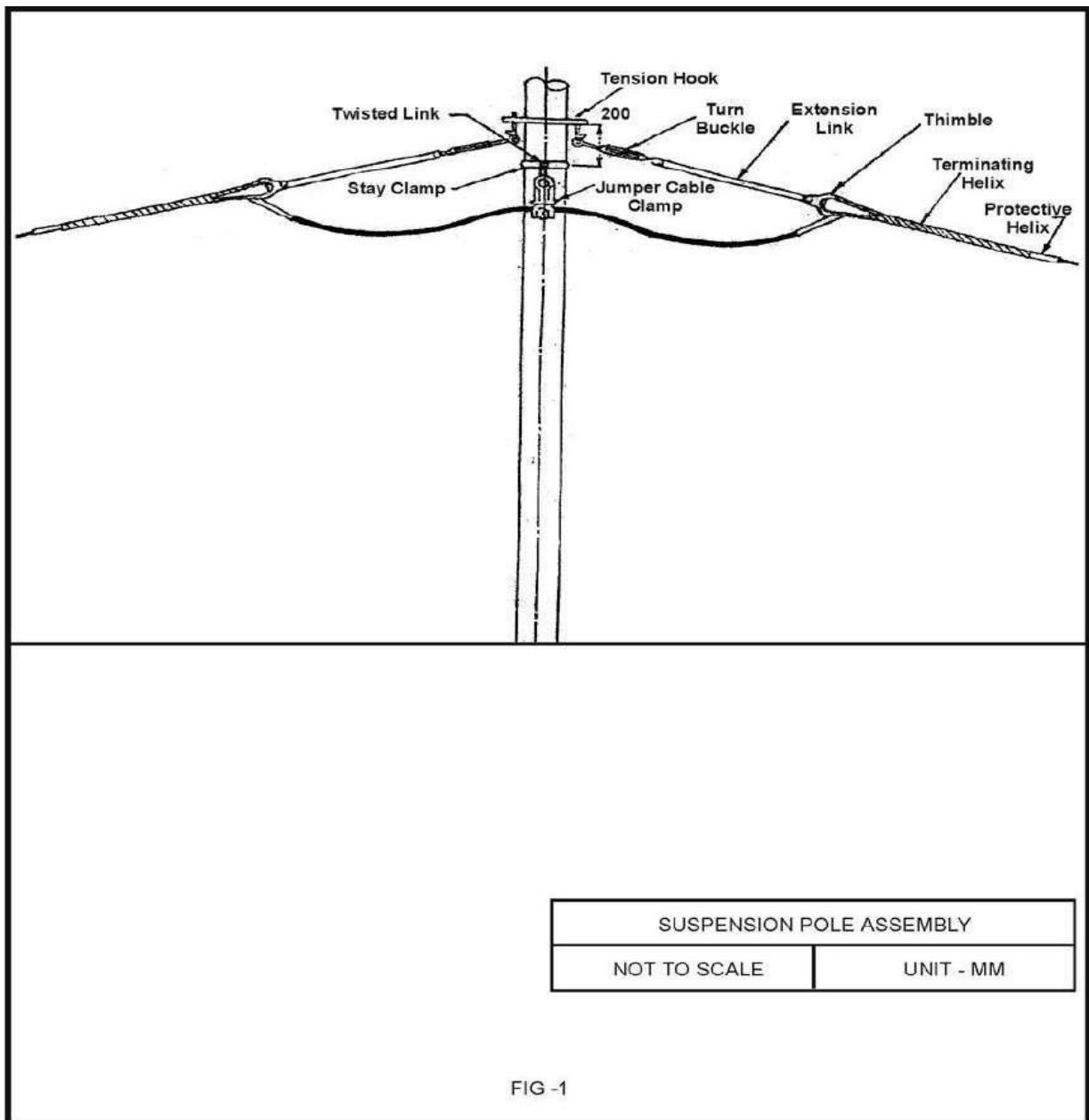

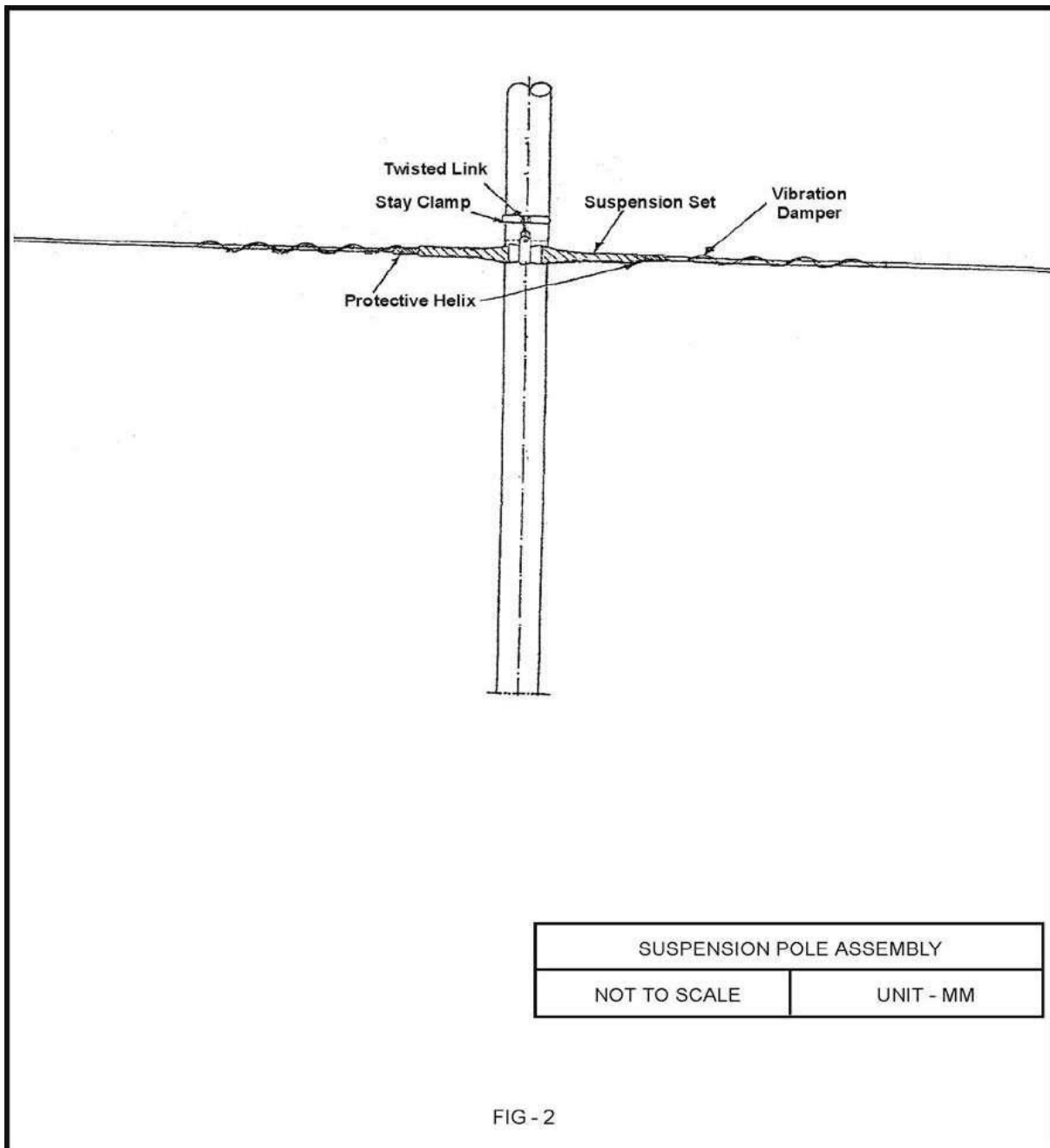

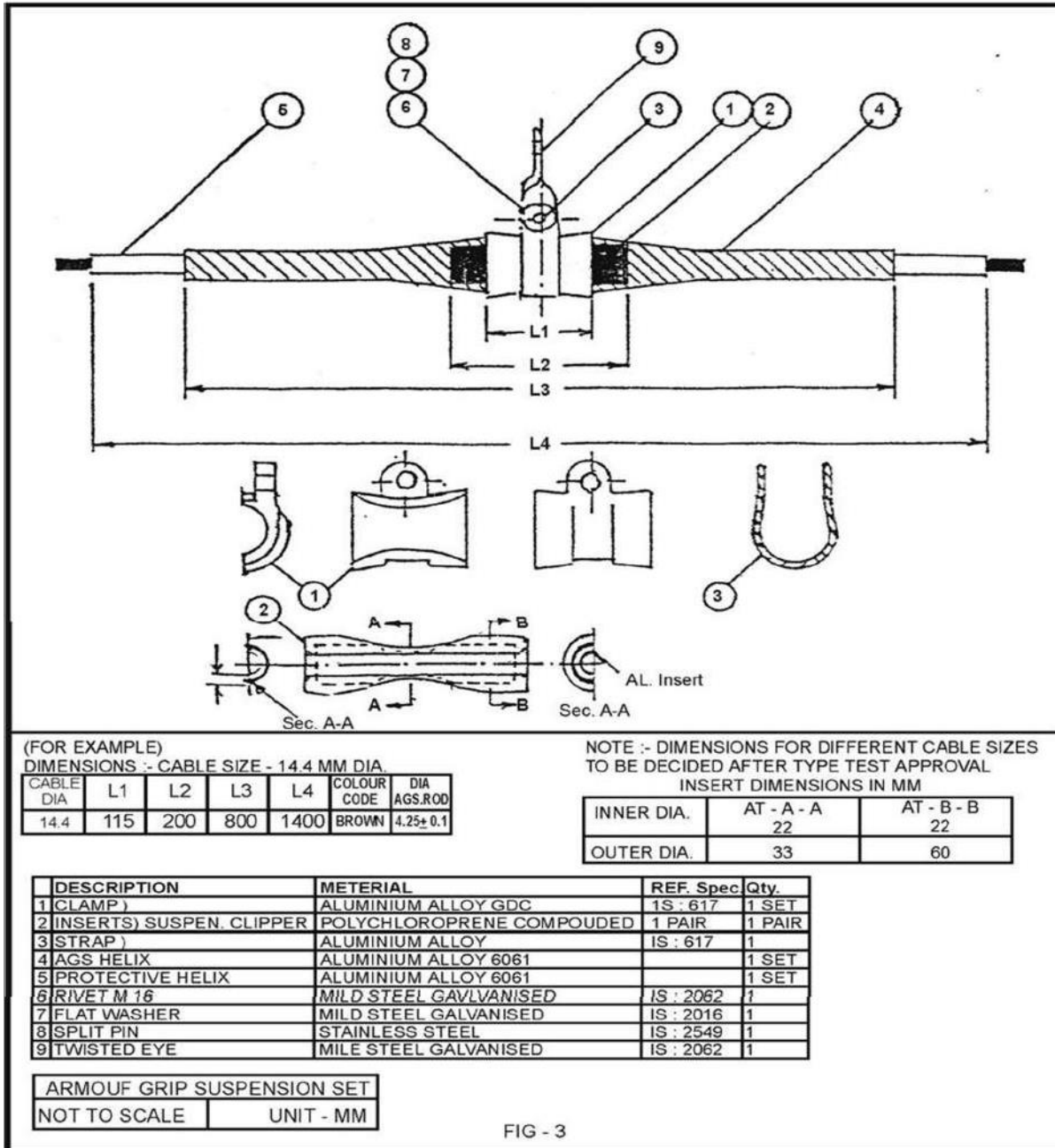

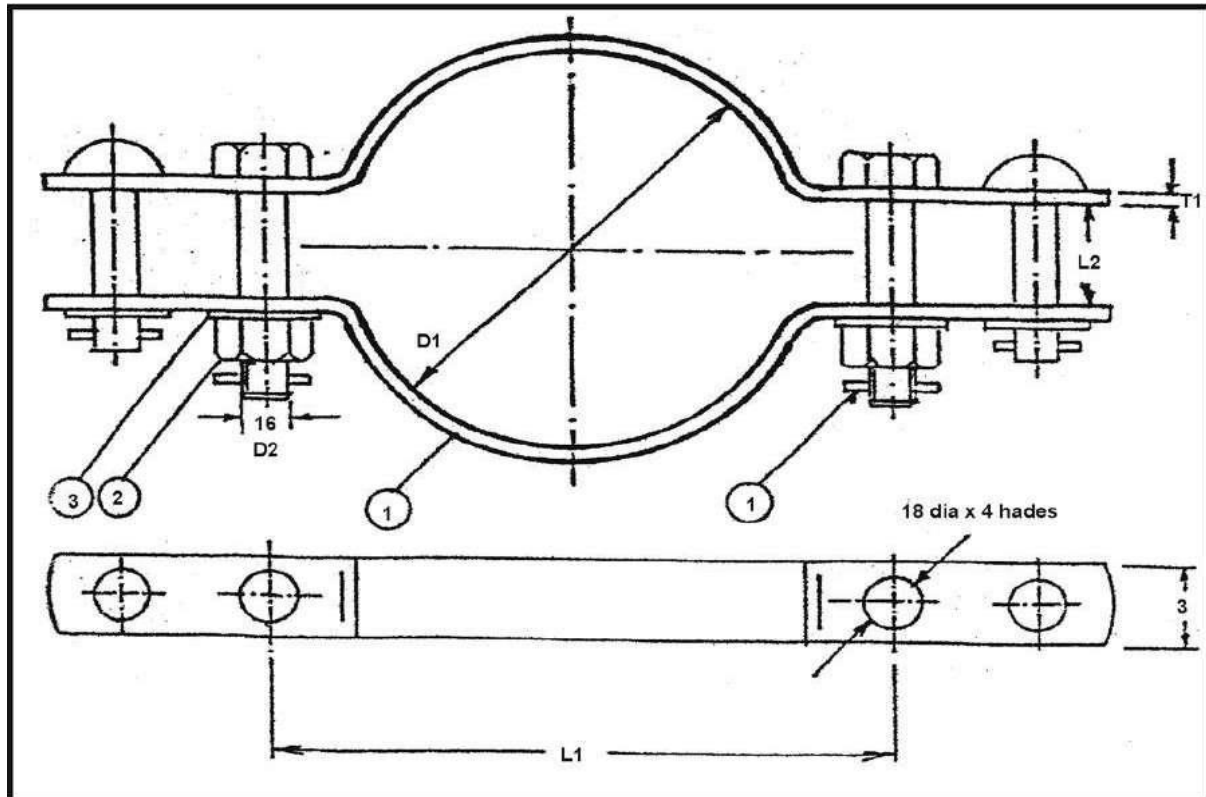

POLE MOUTED STAY CLAMP (RAIL)

L1	L2	L3	L4	L5	L6	L7	L8	T1	T2	D1	W1
270	170	251	151	20	32	50	120	5	20	16	60

NOTE :- TOLERANCE SHALL BE AS PER IS : 2102  
 (DETAIL AS PER GR UNLESS UNTILL SPECIFIED)  
 HOT DIP Galvanised as per is : 2629

DESCRIPTION	METERIAL	REF. Spec.	Qty.
1 CLAMP	MILD STEEL GALVANISED	IS : 2062	1 SET
2 BOLT & NUT M 16	MILD STEEL GALVANISED	IS : 1363	2
3 RIVET 16	MILD STEEL GALVANISED	IS : 2016	2
4 WASHER	MILD STEEL GALVANISED	IS : 2016	4
5 SPILT PIN	STAINLESS STEEL	IS : 549	4

POLE COLLAR CLAMP	
NOT TO SCALE	UNIT - MM

FIG - 4

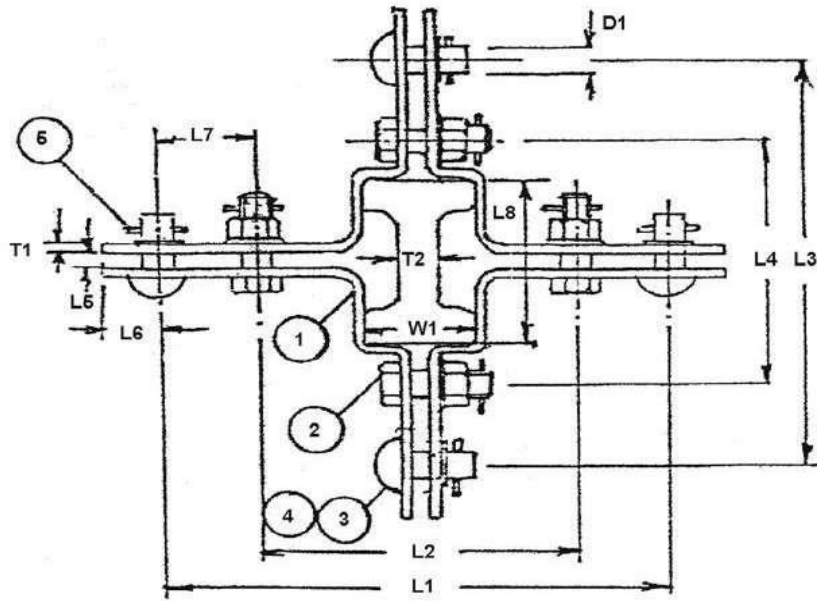

DIMENSIONS IN MM :  
POLE MOUNTED STAY CLAMP TUBULAR

L1	L2	D1	D2	T1	W
210	20	150	16	5	30

NOTE :- TOLERANCE SHALL BE AS PER IS : 2102  
(DETAIL AS PER GR UNLESS UNTILL SPECIFIED)  
HOT DIP GALVANISED AS PER IS : 2629

DESCRIPTION	METERIAL	REF. Spec	Qty.
1 CLAMP	MILD STEEL GALVANISED	IS : 2062	1 SET
2 BOLT & NUT M 16	MILD STEEL GALVANISED	IS : 1363	4
3 RIVET 16	MILD STEEL GALVANISED	IS : 2016	4
4 WASHER	MILD STEEL GALVANISED	IS : 2016	8
5 SPILT PIN	STAINLESS STEEL	IS : 549	8 SET

POLE COLLAR CLAMP (R)	
NOT TO SCALE	UNIT - MM

FIG - 5

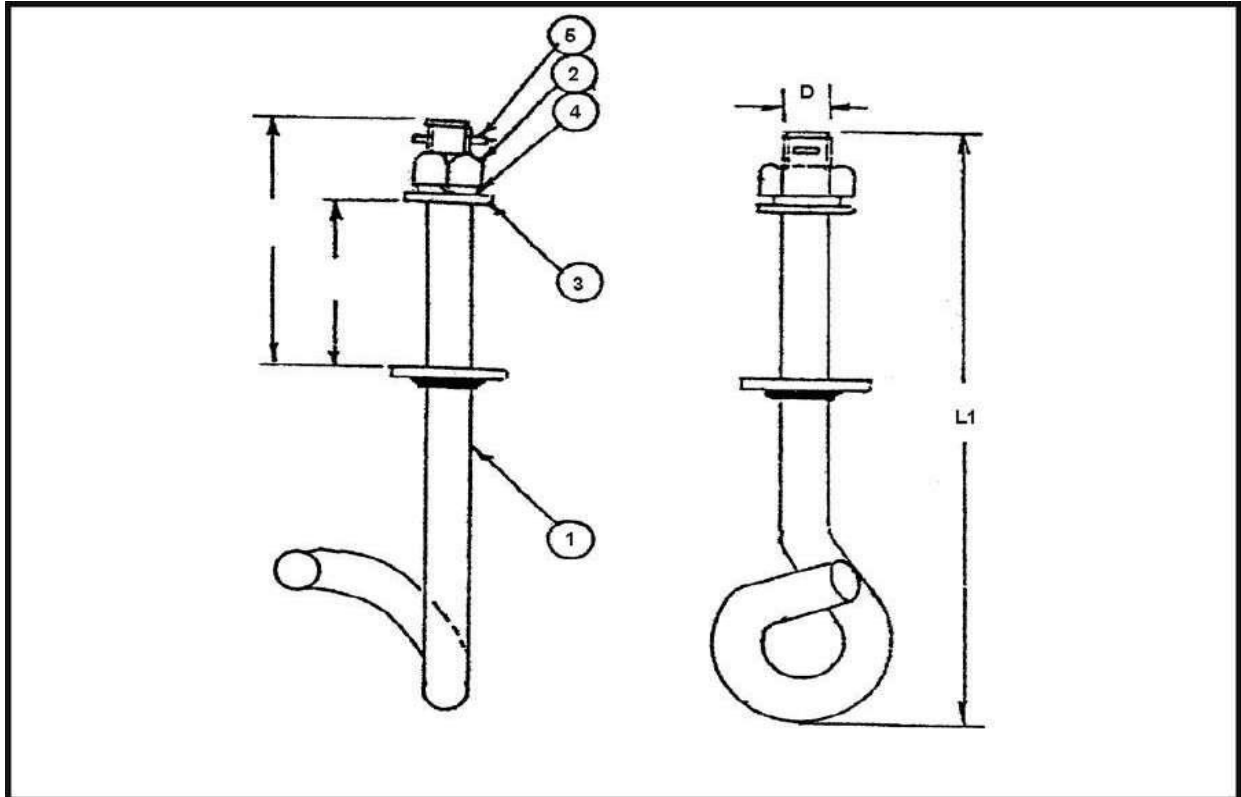

DIMENSIONS IN MM :

L1	L2	L3	D
177	75	50	12

NOTE :- TOLERANCE SHALL BE AS PER IS : 2102  
(DETAIL AS PER GR, UNLESS UNTILL SPECIFIED)

TO BE USED HERE C-BRACKET IS AVAILABLE ON POLE FOR FITMENT OF TENSION HOOK  
HOT DIP GAVANISED AS PER IS : 2629

DESCRIPTION	METERIAL	REF. Spec.	Qty.
1 BODY	ALLOY STEEL GALVANISED	IS : 2004	1
2 NUT	MILD STEEL GALVANISED	IS : 1363	1
3 PLAIN WASHER	MILD STEEL GALVANISED	IS : 2016	1
4 SPRING WASHER	SPRING STEEL GALVANISED	IS : 3063	1
5 SPILT PIN	STAINLESS STEEL	IS : 549	1

TENSION HOOK	
NOT TO SCALE	UNIT - MM

FIG - 6

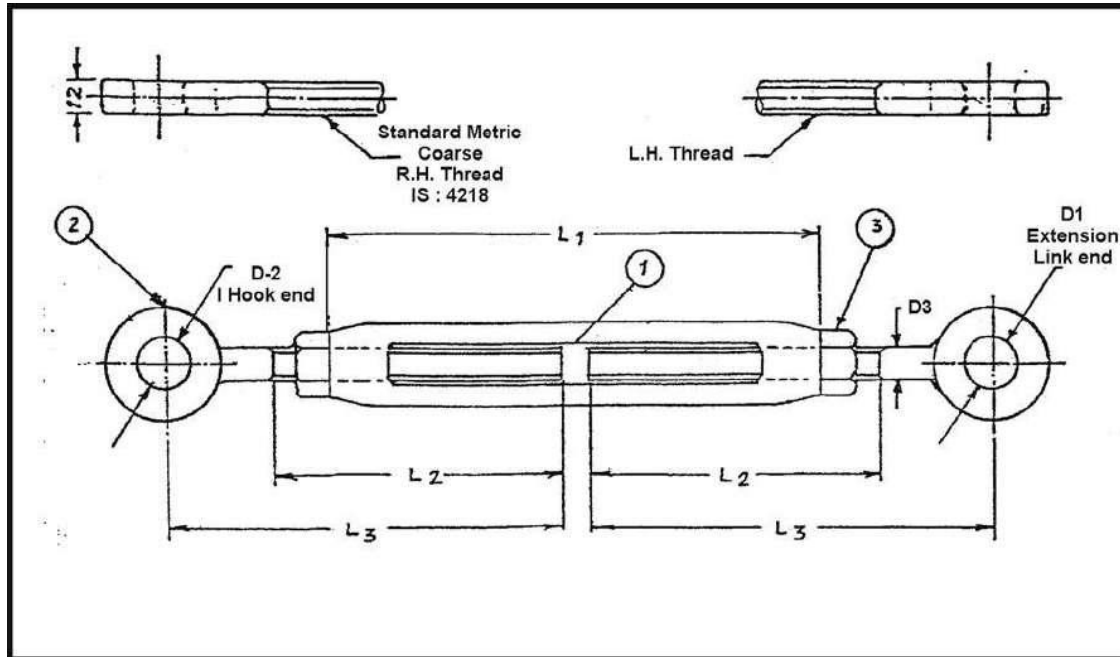

DIMENSIONS IN MM :

L1	L2	L3	D1	D2	D3
170	100	140	18	18	12

NOTE :- TOLERANCE SHALL BE AS PER IS : 2102  
(DETAIL AS PER GR, UNLESS UNTILL SPECIFIED)

MIN. LENGTH : 290 MM  
MAX. LENGTH : 400 MM  
RANGE OF ADI. : 110 MM  
HOT DIP GALVANISED AS PER IS : 2629

DESCRIPTION	METERIAL	REF. Spec	Qty.
1 BODY	MILD STEEL FORGED GLAV.	IS : 2004	1
2 NUT BOLT	MILD STEEL FORGED GLAV.	IS : 2062	2
3 NUT	MILD STEEL	IS : 1363	2

TURN BUCKLE	
NOT TO SCALE	UNIT - MM

FIG - 7

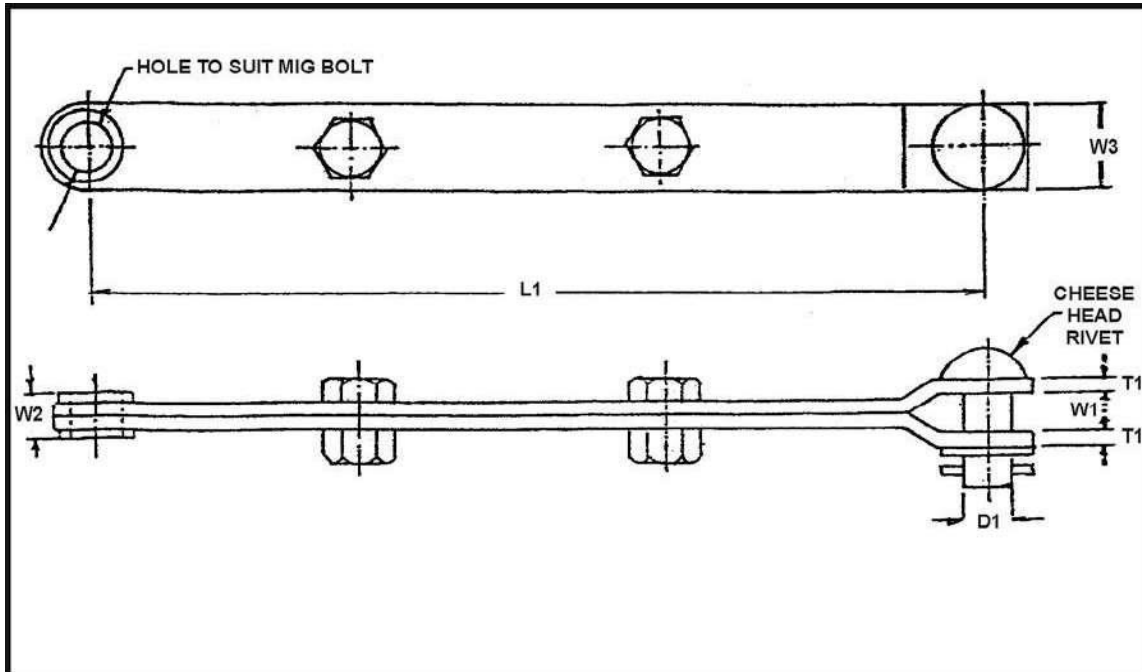

DIMENSIONS IN MM :

L1	T1	W1	W2	W3	D1
465	5	14	16	30	16

NOTE :- TOLERANCE SHALL BE AS PER IS : 2102  
(DETAIL AS PER GR, UNLESS UNTILL SPECIFIED)

HOT DIP GALVANISED AS PER IS : 2629

DESCRIPTION	METERIAL	REF. Spec.	Qty.
1 STRAP	MILD STEEL GALVANISED.	IS : 2067	1
2 RIVET & WASHER	MILD STEEL GALVANISED	IS : 2016	1
3 SPLIT PIN	STAINLESS STEEL	IS : 549	1
4 BOLT & NUT M 16	MILD STEEL GALVANISED	IS : 1363	1

EXTENSION LINK	
NOT TO SCALE	UNIT - MM

FIG - 8

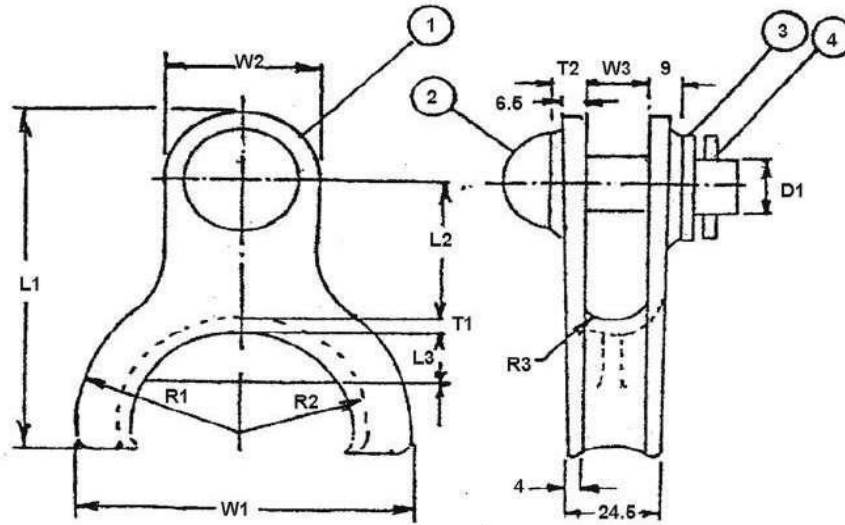

DIMENSIONS IN MM :

L1	L2	L3	T1	T2	R1	R2	R3	W1	W2	W3	D1
102	42	15	4	9	23	15	8	92	40	18	16

NOTE :- TOLERANCE SHALL BE AS PER IS : 2102  
(DETAIL AS PER GR, UNLESS UNTILL SPECIFIED)

FEROUS PARTS ARE HOR DIP GALVANISED  
AS PER IS : 2629

DESCRIPTION	METERIAL	REF. Spec.	Qty.
1 CLAMP	ALUMINIUM ALLOY GDC.	IS : 617	1
2 RIVET M16 x 45	GALV. STEEL	IS : 2016	1
3 WASHER	GALV. STEEL	IS : 2016	1
4 SPLIT PIN	STAINLESS STEEL	IS : 549	1

CLEVIS THIMBLE	
NOT TO SCALE	UNIT - MM

FIG - 9

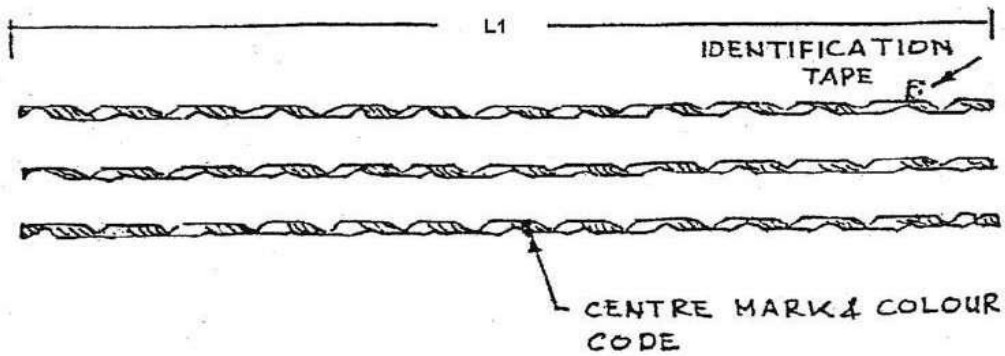

FOR EXAMLE  
DIMENSIONS (FOR CABLE SIZE, D - 14.4 MM)

- I. DIA OF EACH WIRE -  $3.2 \pm 0.1$
- II. NO. OF SETS - 3
- III. NO. OF WIRE PER SET - 5
- IV. LENGTH OF HELIX - 1400

DIMENTION DETAILS FOR OTHER CABLE SIZE SHALL BE INDICATED BY THE MANUFACTURER INCLUDING THE PITCH OF HELIX

NOTE : ENDS OF RODS SHALL BE DEBURRED TOLERANCE SHALL BE AS PER IS : 2102 (DETAIL AS PER GR, UNLESS UNTILL SPECIFIED)

DESCRIPTION	METERIAL	REF. Spec.	Qty.
1 PROTECTIVE HELIX	ALUMINIUM ALLOY 6061		

PROTECTIVE HELIX (S)	
NOT TO SCALE	UNIT - MM

FIG - 10

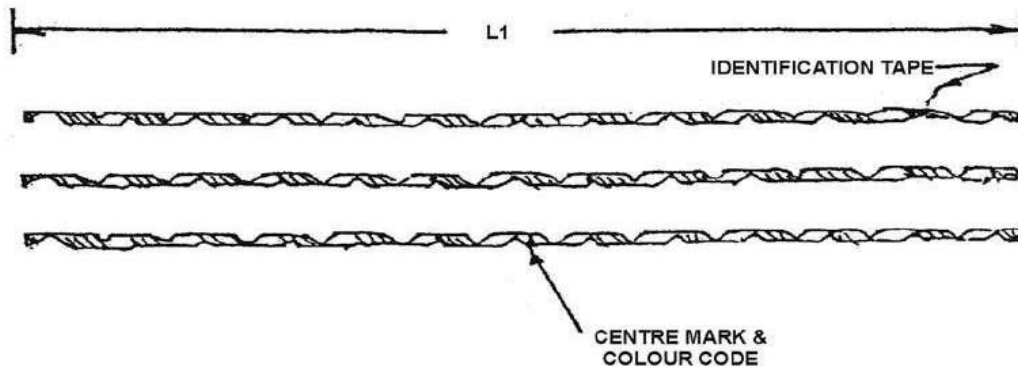

FOR EXAMLE  
DIMENSIONS (FOR CABLE SIZE, D - 14.4 MM)

- I. DIA. OF EACH WIRE -  $3.2 \pm 0.1$
- II. NO. OF SETS - 3
- III. NO. OF WIRE PER SET - 5
- IV. LENGTH OF HELIX - 1000

DIMENTION DETAILS FOR OTHER CABLE SIZE SHALL BE INDICATED BY THE MANUFACTURER INCLUDING THE PITCH OF HELIX

NOTE : ENDS OF RODS SHALL BE DEBURRED TOLERANCE SHALL BE AS PER IS : 2102 (DETAIL AS PER GR, UNLESS UNTILL SPECIFIED)

DESCRIPTION	METERIAL	REF. Spec.	Qty.
1 PROTECTIVE HELIX	ALUMINIUM ALLOY 6061		

PROTECTIVE HELIX (T)	
NOT TO SCALE	UNIT - MM

FIG - 11

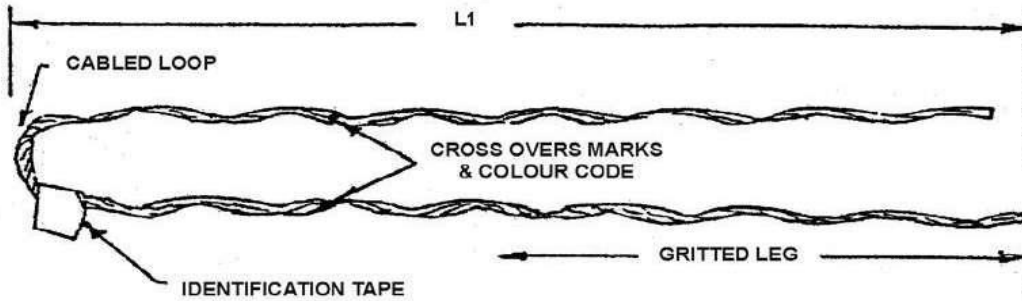

DIMENSIONS  
FOR EXAMPLE

L1	T1
1000	2.2±0.1

D IS DIA OF EACH WIRE ROD  
NO. OF WIRES USED 5

NOTE : TOLERANCE SHALL BE PER IS : 2102  
(DETAIL AS PER GR, UNLESS UNTILL SPECIFIED)

DIMENSION DETAIL FOR DIFFERE CABLE SIZES TO BE DECIDED AP TYPE TEST APPROVAL  
FOR EXAMPLE CABLE SIZE  
ENDS OF RODS SHALL BE DEBUR LENGTH OF TERMINATING HELIX 1000 MM,  
TER MINATING HELIX TO BE USED WITH THIMBLE C DIA - 14.4 MM

DESCRIPTION	METERIAL	REF. Spec.	Qty.
1 DEADEHD GRIP	ALUMINISED STEEL		

TERMINATING HELIX	
NOT TO SCALE	UNIT - MM

FIG - 12

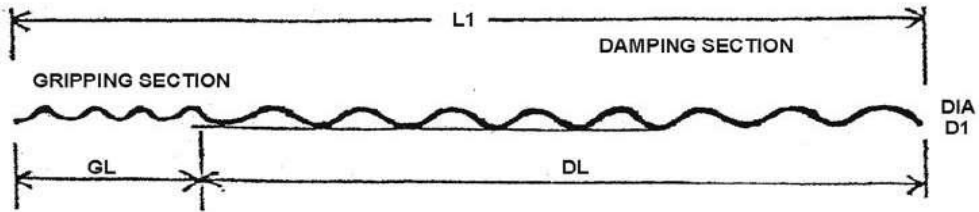

DIMENSIONS IN MM

L1	GL	DL	D1
1346	446	900	12±1

NOTE : TOLERANCE SHALL BE AS PER IS : 2102  
(DETAIL AS PER GR, UNLESS UNTILL SPECIFIED)

DESCRIPTION	MATERIAL	REF. Spec.	Qty.
1 SPIRAL VIBRATION DAMPER	POLYVINYL COPOLYMER		

SPIRAL VIBRATION DAMPER	
NOT TO SCALE	UNIT - MM

FIG - 13

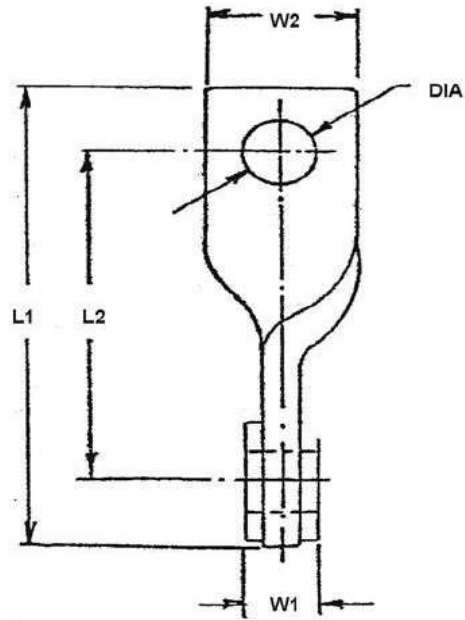

DIMENSIONS IN MM

L1	L2	W1	W2	DIA
138	100	27	38	18

NOTE : TOLERANCE SHALL BE AS PER IS : 2102  
 (DETAIL AS PER GR, UNLESS UNTILL SPECIFIED)  
 HOT DIP GAVANISED AS PER IS : 2629

DESCRIPTION	METERIAL	REF. Spec.	Qty.
1 LINK	MILD STEEL	IS : 2062	1

TWISTED EYE LINK	
NOT TO SCALE	UNIT - MM

FIG - 14

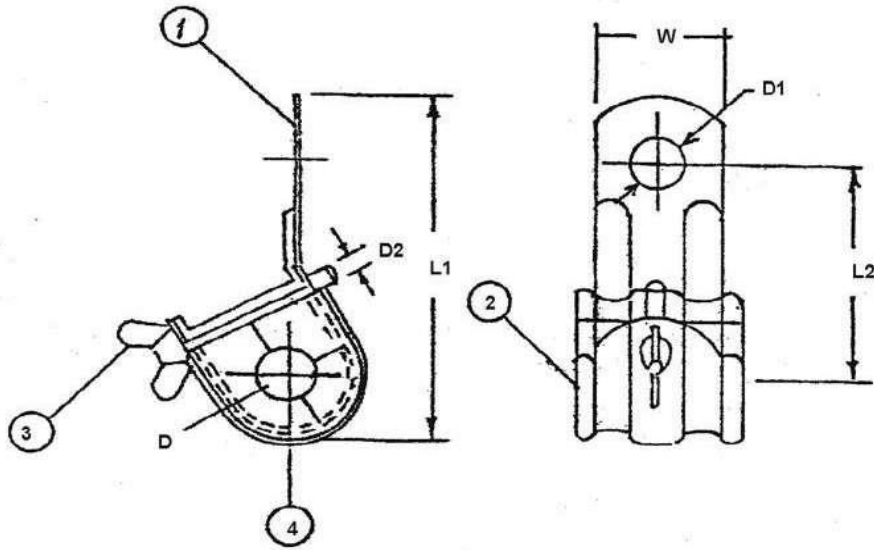

DIMENSIONS IN MM

L1	L2	D1	D2	W
105	65	17.5	5-6	35

DIMENSIONS IN MM OF INSERT PAD

L	INNER DIA	OUTER DIA
40	15	30

NOTE : TOLERANCE SHALL BE AS PER IS : 2102  
(DETAIL AS PER GR, UNLESS UNTILL SPECIFIED)

INSERT IN TOW HALVES D TO SUIT CABLE DIA FERROUS PARTS ARE HOT DIP GALVASIED AS PER IS : 2629

DESCRIPTION	METERIAL	REF. Spec	Qty.
1 STRAP	MILD STEEL GALY	IS : 2062	1
2 INSERT	POLYCHLORADPRENE COMPOUNDED		1
3 WING BOLT	MILD STEEL GALY	IS 2062	1

JUMPER CABLE CLAMP	
NOT TO SCALE	UNIT - MM

FIG - 15

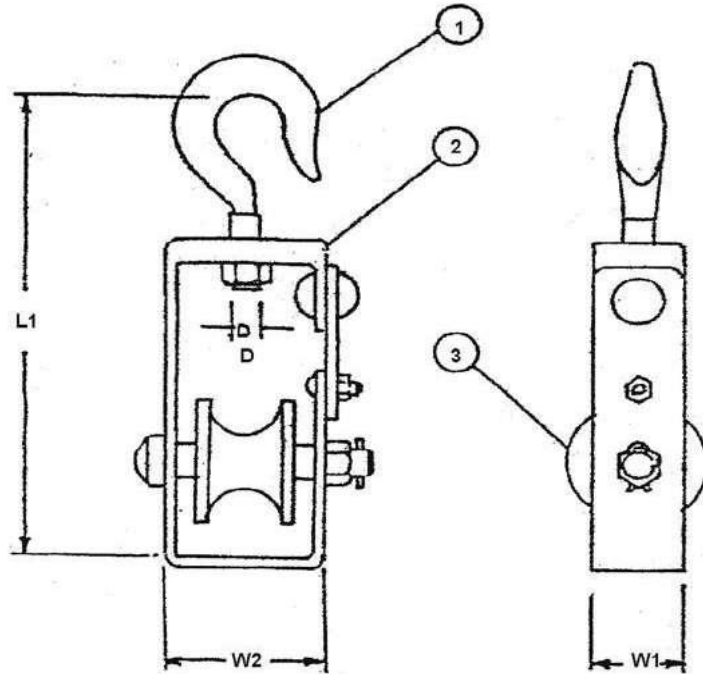

DIMENSIONS IN MM

L1	W1	W2	D
280	50	92	12

NOTE : TOLERANCE SHALL BE AS PER IS : 2102  
 (DETAIL AS PER GR, UNLESS UNTILL SPECIFIED)  
 FEFFOUS PARTS ARE HOT DIP GALVANISED AS PER IS : 2629

DESCRIPTION	METERIAL	REF. Spec.	Qty.
1 HOOK	GALVANISED STEEL		
2 BODY	GALVANISED STEEL		1 SET
3 SPOOL	ALUMINIUM COATED NEOPRENE		

DEMOUNTABLE PULLEY	
NOT TO SCALE	UNIT - MM

FIG - 16

## 4. POST BASED, ADSS ON LT/HT ELECTRICAL POLES

### 4.1 Overview

- a. The location of the tensioner and puller relative to the structure must be selected so that the pole is not overloaded. Where possible, a pulling slope of 75° to 80° is considered good practice. This ratio will minimize the load on the cable, traveler, sheave, or quadrant block, and pole. It may be necessary to place temporary guys to prevent overloading support poles. The reel must be placed in-line with the first two poles of the run to prevent twisting of the cable or any damage to the cable caused by rubbing the sides of the traveler, sheave, or quadrant block groove.
- b. Anchors and pole hardware must be rated above the expected environmental load of the cable, plus a safety factor. In installations where Aeolian vibration could be an issue, the safety factor should be increased. At locations where the cable is tensioned to achieve proper sag, the pole may require a temporary down-guy and anchor to prevent overloading the pole.
- c. Travelers, sheaves, or quadrant blocks are normally attached directly to the support pole. The pole attachment, used to support the traveler, sheave, or quadrant block must be consistent with the working load and rating of the traveler, sheave, or quadrant block.
- d. The pulling grip shall be rated above the maximum pulling tension anticipated. Use the manufacturer's instructions for the proper application. When properly installed, no special preparation of the cable end, or aramid yarns, are required. A matching clevis type swivel should be used to help prevent twisting of the cable during pull-in. The swivel should be of the type that has a break-away tension less than or equal to the cable's rated maximum pulling tension to prevent over tensioning the cable.
- e. Aeolian vibration is a resonant vibration caused by low velocity wind blowing across a cylindrical cable that is under tension. This vibration can cause severe degradation of the cable support hardware. Vibration dampers can be very effective in controlling Aeolian vibrations when used on ADSS cable. Both resonant and interference type vibration control systems will work when properly applied.
- f. Splice locations require additional cable be provided to accommodate lowering the cable to the ground with enough slack to allow splicing inside a splicing van or trailer.
- g. All slack cable storage locations require the installation of slack cable storage brackets. The strand cable storage bracket insures a proper bending radius for the stored fiber optic cable and provides for horizontal storage and tiering for storage of multiple cables and loops. Figure 1 below illustrates slack cable storage.

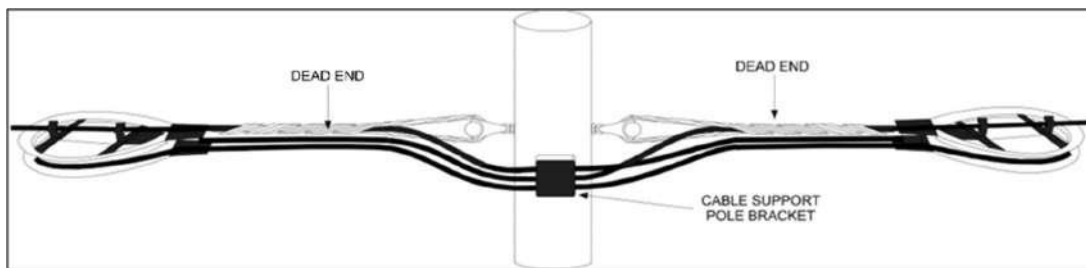

Figure: 1 – Cable Slack Storage

## 4.2 ADSS Cable Support Hardware

There are two general types of ADSS cable support hardware: dead ends and tangent assemblies.

### 4.2.1 Dead-end Assemblies

- a. Dead end assemblies are used at the point of cable termination, or where the cable angle is greater than 20°. See Figure 2 below for illustration of a Dead end Assembly.
- b. The Structural Reinforcement Layer (SRL) is a subset of armor rod that is the first layer applied to the ADSS cable. They are spiraled in a precise twist lay to match the diameter and load of a specific cable. They are normally grouped together in a sub-set of four to five rods, with grit applied to the inside for slip resistance.
- c. The Dead End Grip itself is a set of armor rods that have been formed in a double spiral with a loop at one end. Its precise twist is designed to perfectly match the diameter of the SRL as it lay over the cable. The length of the dead end grip is dependent upon the maximum load. It too has grit applied to the inside for slip resistance.

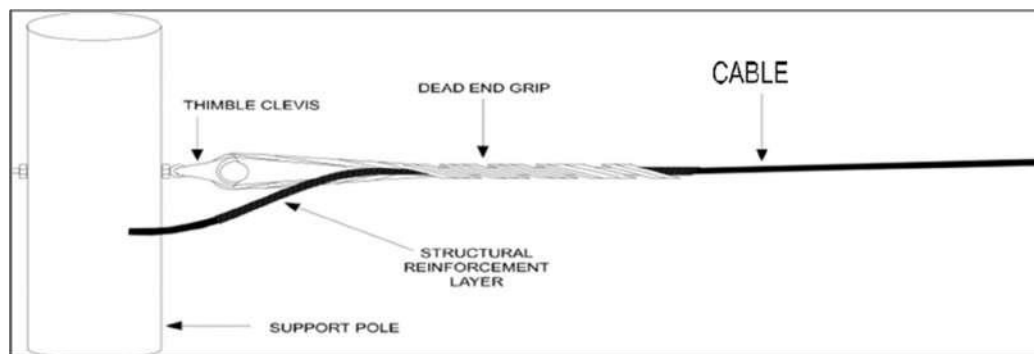

Figure: 2 – Dead end Assembly

- d. The Thimble Clevis is made of cast aluminum or steel and is used to maintain the seat diameter of the dead end loop.
- e. The dead end hardware is assembled in the following manner:
  - i. The SRL rod is assembled on the cable first. The end with the color band is assembled towards the end of the span. Wind on one set of rods at a time. The rods should be placed close together so that there is enough room for them all.

- ii. The tips of the SRL rods should align at the end. Do not force the rods or use tools to install them. Forcing the rods or using tools may damage the cable jacket.
- iii. Align the color band on the dead end with the color band on the SRL and wind one leg of the dead end on approximately two feet.
- iv. Insert the thimble clevis into the loop
- v. Align the color band on the second dead end leg with the color band on the first dead end. Wind the second dead end leg over the SRL for approximately two feet. Continue winding the dead end legs over the SRL until both legs are snapped in place.
- vi. Connect the thimble clevis to the hardware (or to the extension link and then the hardware) mounted on the pole.

#### 4.2.1.1 TANGENT ASSEMBLIES

Tangent hardware is normally installed after the span has been tensioned. Figure 3 below illustrates a front and side view of a Tangent Support. To install the cable, open the hinged top and insert the bottom pad. Then place the cable on the pad, place the top pad over the cable, close the top and tighten the bolt to hold the cable in place.

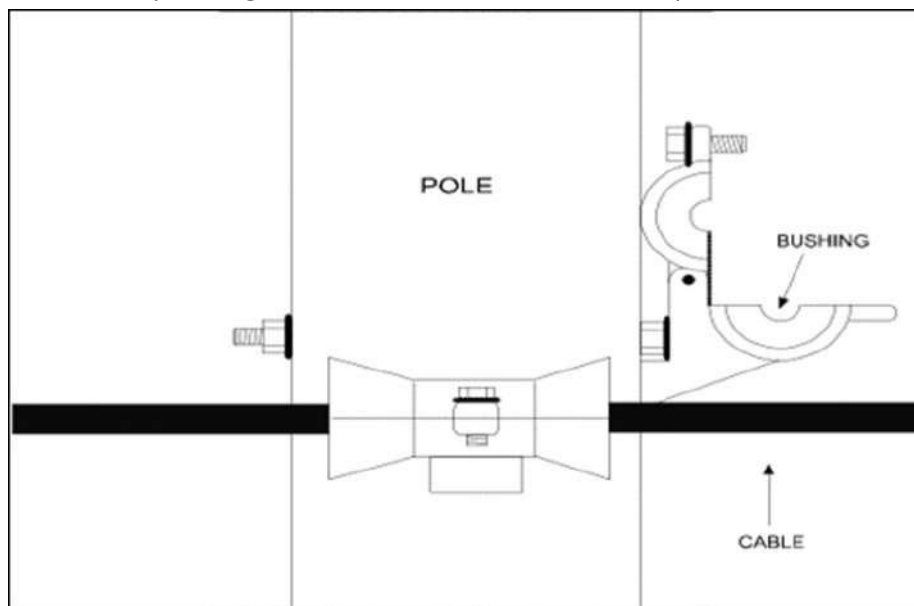

Figure 3

#### 4.2.2 ADSS Sagging and Tensioning

- a. Upon completion of placing the entire run of cable, sagging and tensioning can now be started. Sagging and tensioning the run is worked progressively from one end of the run towards the opposite end. Normally the slack is worked back in the direction of the reel in order to recover as much cable as possible. Sagging and tensioning should be conducted according to the cable manufacturer's recommendations for the cable just installed.
- b. The cable run is broken down into subsections for sagging and tensioning purposes. The last structure at each end of a section being sagged and tensioned is a dead end assembly. Remove

all excess slack cable out of the section of the run being prepared for sagging and tensioning. To remove the slack, reverse the tensioner and pull the cable back towards the reel, being careful not to exceed the minimum bending radius for the cable under tension.

- c. Once the slack is out of the cable, install a temporary dead end on the cable approximately 2 dead end assembly lengths away from the support pole. This dead end will be used as a tensioning grip to achieve proper span sag and tension, prior to installing the permanent dead end assembly.
- d. Attach the tensioning device: a chain hoist or power winch and a dynamometer between the pole and the temporary dead end. Begin to apply tension to the span.
- e. The cable is normally tensioned from dead end to dead end along the span back to the reel. Once the spans are properly sagged and dead ends attached, the suspension or tangent hardware is installed and attached to the poles by working back to the dead end one span at a time.
- f. With a span's permanent dead end installed and the hardware attached to the poles, the pulling device can now have its tension released and the temporary dead ends removed from the cable. When the next permanent dead end is installed on the adjacent span, make sure that the loop formed between the two dead ends maintains the minimum bend radius for the cable. Repeat this operation until all spans are sagged and tensioned.

## 5. CONCLUSION

As All Dielectric Self-supporting Aerial Cable (ADSS) are made of brittle material, so it can't put too much strain and fiber diameter is very small, so the tensile strength is very weak .In choosing the cable hardware, the principle is not only to meet all the features and characteristics of the cable should be inclusive , but shall take into account the payment of grip strength with uniform , non-metallic sheath degradation , wear , vibration breeze , dancing , exceed the allowable bending stress and reverse parameters. Therefore, the general provisions are "Hardware's squeeze should not exceed with more than two cables design limits, hardware should not be designed for a range of diameters."

**FORM OF BID-SECURING DECLARATION**

Date:

[RFP No ..... ]

To  
The ITI LIMITED  
NS Unit  
Bengaluru  
560016

We, the undersigned declare that:

We understand that, according to your conditions, Bids must be supported by a Bid-securing Declaration. We accept that we are required to pay the bid security amount specified in the Term and Condition, failure to do so will automatically exclude us from being eligible for Bidding or submitting Bid in any contract with the employer for the period of two years if we are in breach of our obligation(s) under the term and condition prescribe for ticketing vide invitation letter no:

.....

- a) Have withdrawn our Bid during the period of Bid validity specified by the Bidder in the Form of Bid; or
- b) Having not accepted the correction of errors in accordance with the instructions to Bidders ITB or
- c) Having been notified of the acceptance of our Bid by the Employer during the period of Bid validity.
- i) Fail or refuse to furnish the performance security in accordance with the ITT, or
- ii) Fail or refuse to execute the contract in accordance with the ITB.

We understand this Bid-Securing Declaration shall expire if we are not the successful Bidder, upon the earlier of

- i) Our receipt of your notification to us of the name of the successful Bidder: or
- ii) Thirty (30) days after the expiration of our Bid.

Sign and Seal  
Name of Authorized Official  
Legal Stamp

**ANNUAL FINANCIAL TURN OVER FOR LAST THREE YEARS.**

Sl. No.	Financial year	Turnover	Average of three years
1	2022-23		
2	2023-24		
3	2024-25		

**Note:**

In addition to the above, the applicant has to submit the following documents/information,

- a. Copy of the balance sheets
- b. Copy of the valid GST no.
- c. Copy of the PAN.
- d. Other relevant details if any.

***The requisite Turnover certificate shall be duly certified by a Chartered Accountant with his seal /Signature and Registration No.***

**Signature of the bidder with Seal**

**DETAILS OF THE WORK COMPLETED DURING THE LAST 7 YEARS**

Sl. No.	Name of work	Scope of services	Value of work	Date of start/completion	Name and address of the client	Value of TDS in case of private work	Remarks

**NOTE:**

The following documents are to be enclosed for each of the above works.

- a. Work Completion certificate.
- b. Copy of award letter and PO/WO copy.
- c. Other relevant documentary evidence, if any.

**Signature of the bidder with Seal**

**PRE CONTRACT INTEGRITY PACT**

PURCHASE ENQUIRY/ORDER No.

THIS Integrity Pact is made on.....day of ..... 20.

**BETWEEN:**

ITI Limited having its Registered & Corporate Office at ITI Bhavan, Dooravaninagar, Bangalore – 560 016 and established under the Ministry of Communications, Government of India (hereinafter called the Principal), which term shall unless excluded by or is repugnant to the context, be deemed to include its Chairman & Managing Director, Directors, Officers or any of them specified by the Chairman & Managing Director in this behalf and shall also include its successors and assigns) ON THE ONE PART

**AND:**

..... represented by.....Chief Executive Officer (hereinafter called the Contractor(s), which term shall unless excluded by or is repugnant to the context be deemed to include its heirs, representatives, successors and assigns of the bidder/contract ON THE SECOND PART.

**Preamble**

WHEREAS the Principal intends to award, under laid down organizational procedures, contract for

..... of ITI Limited (name of the Stores/equipment's/items). The Principal, values full compliance with all relevant laws of the land, regulations, economic use of resources and of fairness/ transparency in its relations with its Bidder(s)/ Contractor(s).

In order to achieve these goals, the Principal has appointed an Independent External Monitor(IEM), who will **monitor** the tender process and the execution of the contract for compliance with the principles as mentioned herein this agreement.

WHEREAS, to meet the purpose aforesaid, both the parties have agreed to enter into this Integrity Pact the terms and conditions of which shall also be read as integral part and parcel of the Tender Documents and contract between the parties.

**NOW THEREFORE, IN CONSIDERATION OF MUTUAL COVENANTS STIPULATED IN THIS PACT THE PARTIES HEREBY AGREE AS FOLLOWS AND THIS PACT WITNESSETH AS UNDER:**

**SECTION 1 – COMMITMENTS OF THE PRINCIPAL**

- 1.1 The Principal commits itself to take all measures necessary to prevent corruption and to observe the following principles:
- a. No employee of the Principal, personally or through family members, will in connection with the tender for or the execution of the contract, demand, take a promise for or accept, for self or third person, any material or immaterial benefit which the personal is not legally entitled to.
  - b. The Principal will, during the tender process treat all bidder(s) with equity and reason. The Principal will in particular, before and during the tender process, provide to all bidder(s) the same information and will not provide to any bidder(s) confidential/additional information through which the bidder(s) could obtain an advantage in relation to the tender process or the contract execution.
  - c. The Principal will exclude from the process all known prejudiced persons.
- 1.2 If the Principal obtains information on the conduct of any of its employee, which is a criminal offence under IPC/PC Actor if there be a substantive suspicion in this regard, the Principal will inform the Chief Vigilance Officer and in addition can initiate disciplinary action as per its internal laid down Rules/ Regulations.

**SECTION 2 – COMMITMENTS OF THE BIDDER/CONTRACTOR**

- 2.1 The Bidder(s)/Contractor(s) commits himself to take all measures necessary to prevent corruption. He commits himself observe the following principles during the participation in the tender process and during the execution of the contract.
- a. The bidder(s)/contractor(s) will not, directly or through any other person or firm offer, promise or give to any of the Principal's employees involved in the tender process or the execution of the contract or to any third person any material or other benefit which he/she is not legally entitled to, in order to obtain in exchange any advantage of any kind whatsoever during the tender process or during the execution of the contract.
  - b. The bidder(s)/contractor(s) will not enter with other bidders/contractors into any undisclosed agreement or understanding, whether formal or informal. This applies in particular to prices, specifications, certifications, subsidiary contracts, submission or non-submission of bids or any other actions to restrict competitiveness or to introduce cartelization in the bidding process.

- c. The bidder(s)/contractor(s) will not commit any offence under IPC/PC Act, further the bidder(s)/contractor(s) will not use improperly, for purposes of competition of personal gain, or pass onto others, any information or document provided by the Principal as part of the business relationship, regarding plans, technical proposals and business details, including information contained or transmitted electronically.
- d. The Bidder(s)/Contractor(s) of foreign origin shall disclose the name and address of the agents/representatives in India, if any. Similarly, the Bidder(s)/Contractor(s) of Indian Nationality shall furnish the name and address of the foreign principals, if any.
- e. The Bidder(s)/Contractor(s) will, when presenting the bid, disclose any and all payments made, are committed to or intend to make to agents, brokers or any other intermediaries in connection with the award of the contract.
- f. The Bidder(s)/Contractor(s) will not bring any outside influence and Govt bodies directly or indirectly on the bidding process in furtherance to his bid.
- g. The Bidder(s)/Contractor(s) will not instigate third persons to commit offences outlined above or to be an accessory to such offences.

### **SECTION 3 – DISQUALIFICATION FROM TENDER PROCESS & EXCLUSION FROM FUTURE CONTRACTS**

- 3.1 If the Bidder(s)/Contractor(s), during tender process or before the award of the contract or during execution has committed a transgression in violation of Section 2, above or in any other form such as to put his reliability or credibility in question the Principal is entitled to disqualify Bidder(s)/ Contractor(s) from the tender process.
- 3.2 If the Bidder(s)/Contractor(s), has committed a transgression through a violation of Section 2 of the above, such as to put his reliability or credibility into question, the Principal shall be entitled exclude including blacklisting for future tender/contract award process. The imposition and duration of the exclusion will be determined by the severity of the transgression. The severity will be determined by the Principal taking into consideration the full facts and circumstances of each case, particularly taking into account the number of transgression, the position of the transgressor within the company hierarchy of the Bidder(s)/Contractor(s) and the amount of the damage. The exclusion will be imposed for a period of minimum one year.
- 3.3 The Bidder(s)/Contractor(s)with its free consent and without any influence agrees and undertakes to respect and uphold the Principal’s absolute right to resort to and impose such

exclusion and further accepts and undertakes not to challenge or question such exclusion on any ground including the lack of any hearing before the decision to resort to such exclusion is taken. The undertaking is given freely and after obtaining independent legal advice.

- 3.4 A transgression is considered to have occurred if the Principal after due consideration of the available evidence concludes that on the basis of facts available there are no material doubts.
- 3.5 The decision of the Principal to the effect that breach of the provisions of this Integrity Pact has been committed by the Bidder(s)/ Contractor(s) shall be final and binding on the Bidder(s)/ Contractor(s), however the Bidder(s)/ Contractor(s) can approach IEM(s) appointed for the purpose of this Pact.
- 3.6 On occurrence of any sanctions/ disqualifications etc arising out from violation of integrity pact Bidder(s)/ Contractor(s) shall not entitled for any compensation on this account.
- 3.7 subject to full satisfaction of the Principal, the exclusion of the Bidder(s)/ Contractor(s) could be revoked by the Principal if the Bidder(s)/ Contractor(s) can prove that he has restored/ recouped the damage caused by him and has installed a suitable corruption preventative system in his organization.

#### **SECTION 4 – PREVIOUS TRANSGRESSION**

- 4.1 The Bidder(s)/ Contractor(s) declares that no previous transgression occurred in the last 3 years immediately before signing of this Integrity Pact with any other company in any country conforming to the anti-corruption/ transparency International (TI) approach or with any other Public Sector Enterprises/ Undertaking in India of any Government Department in India that could justify his exclusion from the tender process.
- 4.2 If the Bidder(s)/ Contractor(s) makes incorrect statement on this subject, he can be disqualified from the tender process or action for his exclusion can be taken as mentioned under Section-3 of the above for transgressions of Section-2 of the above and shall be liable for compensation for damages as per Section- 5 of this Pact.

#### **SECTION 5 – COMPENSATION FOR DAMAGE**

- 5.1 If the Principal has disqualified the Bidder(s)/Contractor(s) from the tender process prior to the award according to Section 3 the Principal is entitled to forfeit the Earnest Money Deposit/Bid Security/ or demand and recover the damages equitant to Earnest Money

Deposit/Bid Security apart from any other legal that may have accrued to the Principal.

- 5.2 In addition to 5.1 above the Principal shall be entitled to take recourse to the relevant provision of the contract related to termination of Contract due to Contractor default. In such case, the Principal shall be entitled to forfeit the Performance Bank Guarantee of the Contractor or demand and recover liquidate and all damages as per the provisions of the contract agreement against termination.

#### **SECTION 6 – EQUAL TREATMENT OF ALL BIDDERS/CONTRACTORS**

- 6.1 The Principal will enter into Integrity Pact on all identical terms with all bidders and contractors for identical cases.
- 6.2 The Bidder(s)/Contractor(s) undertakes to get this Pact signed by its sub-contractor(s)/sub-vendor(s)/associate(s), if any, and to submit the same to the Principal along with the tender document/contract before signing the contract. The Bidder(s)/Contractor(s) shall be responsible for any violation(s) of the provisions laid down in the Integrity Pact Agreement by any of its sub-contractors/sub-vendors/associates.
- 6.3 The Principal will disqualify from the tender process all bidders who do not sign this Integrity Pact or violate its provisions.

#### **SECTION 7 – CRIMINAL CHARGES AGAINST VIOLATING BIDDER(S)/ CONTRACTOR(S)**

If the Principal receives any information of conduct of a Bidder(s)/Contractor(s) or sub-contractor/sub-vendor/associates of the Bidder(s)/Contractor(s) which constitutes corruption or if the Principal has substantive suspicion in this regard, the Principal will inform the same to the Chief Vigilance Officer of the Principal for appropriate action.

#### **SECTION 8 – INDEPENDENT EXTERNAL MONITOR(S)**

- 8.1 The Principal appoints competent and credible Independent External Monitor(s) for this Pact. The task of the Monitor is to review independently and objectively, whether and to what extent the parties comply with the obligations under this pact.
- 8.2 The Monitor is not subject to any instructions by the representatives of the parties and performs his functions neutrally and independently. He will report to the Chairman and Managing Director of the Principal.

- 8.3 The Bidder(s)/Contractor(s) accepts that the Monitor has the right to access without restriction to all product documentation of the Principal including that provided by the Bidder(s)/Contractor(s). The Bidder(s)/Contractor(s) will also grant the Monitor, upon his request and demonstration of a valid interest, unrestricted and unconditional access to his project documentation. The Monitor is under contractual obligation to treat the information and documents Bidder(s)/Contractor(s) with confidentiality.
- 8.4 The Principal will provide to the Monitor sufficient information about all meetings among the parties related to the project provided such meeting could have an impact on the contractual relations between the Principal and the Bidder(s)/Contractor(s). As soon as the Monitor notices, or believes to notice, a violation of this agreement, he will so inform the Management of the Principal and request the Management to discontinue or take corrective action, or to take other relevant action. The monitor can in this regard submit non-binding recommendations. Beyond this, the Monitor has no right to demand from the parties that they act in specific manner, refrain from action or tolerate action.
- 8.5 The Monitor will submit a written report to the Chairman & Managing Director of the Principal within a reasonable time from the date of reference or intimation to him by the principal and, should the occasion arise, submit proposals for correcting problematic situations.
- 8.6 If the Monitor has reported to the Chairman & Managing Director of the Principal a substantiated suspicion of an offence under relevant IPC/PC Act, and the Chairman & Managing Director of the Principal has not, within the reasonable time taken visible action to proceed against such offence or reported it to the Chief Vigilance Officer, the Monitor may also transmit this information directly to the Central Vigilance Commissioner.
- 8.7 The word '**Monitor**' would include both singular and plural.
- 8.8 Details of the Independent External Monitor appointed by the Principal at present is furnished below: - IEM I  
Shri Atul Jundall, IFS (Retd.)  
3/10 Vishesh Khand Opp. Little Friend  
School Gomti Nagar, Lucknow-  
226010(UP)
- IEM II  
Shri Benny John, IRS (Retd.),

Villa No. 36, Kent Plam Villas,  
Fort Valley Township, Athani,  
Kakkanad, Ernakulam, Kerala- 682 030

Any changes to the same as required / desired by statutory authorities is applicable.

#### **SECTION 9 – FACILITATION OF INVESTIGATION**

- 9.1 In case of any allegation of violation of any provisions of this Pact or payment of commission, the Principal or its agencies shall be entitled to examine all the documents including the Books of Accounts of the Bidder(s)/Contractor(s) and the Bidder(s)/Contractor(s) shall provide necessary information and documents in English and shall extend all help to the Principal for the purpose of verification of the documents.

#### **SECTION 10 – LAW AND JURISDICTION**

- 10.1 The Pact is subject to the Law as applicable in Indian Territory. The place of performance and jurisdiction shall be the seat of the Principal.
- 10.2 The actions stipulated in this Pact are without prejudice to any other legal action that may follow in accordance with the provisions of the extant law in force relating to any civil or criminal proceedings.

#### **SECTION 11 – PACT DURATION**

- 11.1 This Pact begins when both the parties have legally signed it. It expires after 12 months on completion of the warranty/guarantee period of the project / work awarded, to the fullest satisfaction of the Principal.
- 11.2 If the Bidder(s)/Contractor(s) is unsuccessful, the Pact will automatically become invalid after three months on evidence of failure on the part of the Bidder(s)/Contractor(s).
- 11.3 If any claim is lodged/made during the validity of the Pact, the same shall be binding and continue to be valid despite the lapse of the Pact unless it is discharged/determined by the Chairman and Managing Director of the Principal.

#### **SECTION 12 – OTHER PROVISIONS**

- 12.1 This pact is subject to Indian Law, place of performance and jurisdiction is the Registered & Corporate Office of the Principal at Bengaluru.
- 12.2 Changes and supplements as well as termination notices need to be made in writing by both the

parties. Side agreements have not been made.

12.3 If the Bidder(s)/Contractor(s) or a partnership, the pact must be signed by all members and partners.

12.4 Should one or several provisions of this pact turn out to be invalid, the remainder of this pact remains valid. In this case, the parties will strive to come to an agreement to their original intentions.

12.3 Any disputes/ difference arising between the parties with regard to term of this Pact, any action taken by the Principal in accordance with this Pact or interpretation thereof shall not be subject to any Arbitration.

12.4 The action stipulates in this Integrity Pact are without prejudice to any other legal action that may follow in accordance with the provisions of the extant law in force relating to any civil or criminal proceedings.

In witness whereof the parties have signed and executed this Pact at the place and date first done mentioned in the presence of the witnesses:

For PRINCIPAL

For BIDDER(S)/CONTRACTOR(S)

.....

.....

(Name & Designation)

(Name & Designation)

Witness

Witness

1) .....

1).....

2) .....

2).....

**MUTUAL NON- DISCLOSURE AGREEMENT**

This Agreement is made as of the ----- 2026 between ITI Ltd. having its registered and corporate office at Dooravani Nagar, Bangalore-560016

And-----hereinafter called ITI Ltd. which expression shall unless repugnant to the subject or the context mean and included its successors, nominees or assigns and (M/s ----- ) a company having its registered office at -----herein after called “The Bidder” which expression shall unless repugnant to the subject or the context mean and include its successors, nominees or assigns.

Whereas in order to pursue the mutual business purpose of this particular Consultancy as specified in Exhibit A (the “Business Purpose”), ITI Ltd. and

M/s -----

-----recognize that there is a need to disclose to one another certain information, as defined in Para 1

below, of each party to be used only for the Business purpose and to protect such confidential information from unauthorized use and disclosure.

In consideration of the other party’s disclosure of such information, each party agrees as follows:

This Agreement will apply to all confidential and proprietary information disclosed by one party to the other party, including information listed in Exhibit A attached hereto and other information which the disclosing party identifies in writing or otherwise as confidential before or within thirty days after disclosure to the receiving party (“Confidential information”).

Information consists of certain specifications, designs, plans, drawings and /or technical information, and all copies and derivatives containing such information, that may be disclosed to one another for and during the purpose, which a party considers proprietary or confidential (“Information”).

Information may be in any form or medium, tangible or intangible, and may be

Communicated/disclosed in writing, orally, or through visual observation or by any other means to one party (hereinafter referred to as the receiving party) by the other party (hereinafter referred to as one disclosing party). Information shall be subject to this Agreement, if it is in tangible form, only if clearly marked as proprietary or confidential as the case may be, when disclosed to the receiving party or, if not in tangible form, its proprietary nature must first be announced, and it must be reduced to writing and furnished to the receiving party within thirty (30) days of the initial disclosure.

M/s----- and ITI Ltd hereby agreed at during the Confidentiality Period:

ITI Ltd. RFP. No. \_\_\_\_\_

The receiving party shall use Information only for the Purpose, shall hold Information in confidence using the same degree of care as it normally exercises to protect its own proprietary information, but not less than reasonable care, taking into account the nature of the Information, and shall grant access to Information only to its employees who have a need to know, but only to the extent necessary to carry out the business purpose of this project as defined in exhibit A, shall cause its employees to comply with the provisions of this Agreement applicable to the receiving party, shall reproduce Information only to the extent essential to fulfilling the purpose, and shall prevent disclosure of information to third parties.

Upon the disclosing party’s request, the receiving party shall either return to the disclosing party all Information or shall certify to the disclosing party that all media containing Information have been

destroyed. Provided, however. That an archival copy of the Information may be retained in the files of the receiving party's counsel, solely for the purpose of proving the contents of the Information.

The foregoing restrictions on each party's use or disclosure of Information shall not apply to Information that the receiving party can demonstrate

was independently developed by or for the receiving party without reference to the Information, or was received without restrictions; or has become generally available to the public without breach of confidentiality obligations of the receiving party; or was in the receiving party's possession without restriction or was known by the receiving party without restriction at the time of disclosure; or

is the subject of a subpoena or other legal or administrative demand for disclosure; provided, however that the receiving party has given the disclosing party prompt notice of such demand for disclosure and the receiving party reasonably cooperates with the disclosing party's efforts to secure and appropriate protective order; or is disclosed with the prior consent of the disclosing party; or

was in its possession or known to it by being in its use or being recorded in its files or computers or other recording media prior to receipt from the disclosing party and was not previously acquired by the receiving party from the disclosing party under an obligation of confidence; or the receiving party obtains or has available from a source other than the disclosing party without breach by the receiving party or such source of any obligation of confidentiality or non-use towards the disclosing party.

Each party agrees not to remove any of the other party's Confidential Information from the premises of the disclosing party without the disclosing party's prior written approval. Each party agrees to exercise extreme care in ITI Ltd. RFP. No. \_Protecting the confidentiality of any confidential information, which is removed, only with the disclosing party's prior written approval, from the disclosing party's premises. Each party agrees to comply with any and all terms and conditions the disclosing party's may impose upon any such approved removal, such as conditions that the removed confidential information and all copies must be returned by a certain date, and that no copies are to be make off of the premises.

Upon the disclosing party's request, the receiving party will promptly return to the disclosing party all tangible items containing or consisting of the disclosing party's confidential information all copies thereof.

Each party recognizes and agrees that all of the disclosing party's confidential information is owned solely by the disclosing party (or its licensors) and that the unauthorized disclosure or use of such confidential information would cause irreparable harm and significant injury, the degree of which may be difficult to ascertain. Accordingly, each party agrees that the disclosing party will have the right to obtain an immediate injunction enjoining any breach of this agreement, as well as the right to pursue any and all other rights and remedies available at law or in equity for such a breach.

Access to information hereunder shall not preclude an individual who has seen such information for the purpose of this agreement from working on future projects for the receiving party which relate to similar subject matters provided that such individual does not make reference to the information and does not copy the substance of the information during the confidentiality period. Furthermore, nothing contained herein shall be construed as imposing any restriction on the receiving party's disclosure or use of any general learning, skills or know how developed by the receiving party's personnel under this

agreement, if such disclosure and use would be regarded by a person of ordinary skill in the relevant area as not constituting a disclosure or use of the information.

As between the parties, all information shall remain the property of the disclosing party. By disclosing information or executing this agreement, the disclosing party does not grant any license, explicitly or implicitly, under any trademark, patent, copyright, mask work protection rights, trade secret or any other intellectual property right. THE DISCLOSING PARTY DISCLAIMS ALL WARRANTIES REGARDING THE INFORMATION, INCLUDING ALL WARRANTIES WITH RESPECT TO INFRINGEMENT OF INTELLECTUAL PROPERTY RIGHTS AND ALL WARRANTIES AS TO THE ACCURACY OR UTILITY OF SUCH INFORMATION.

Execution of this agreement and the disclosure of information pursuant to this agreement does not constitute or imply any commitment, promise, or inducement by either party to make any purchase, or sale or to enter into any additional agreement of any kind.

Either party's failure to enforce any provision, right or remedy under this agreement shall not constitute a waiver of such provision, right or remedy.

This Agreement will be construed in, interpreted and applied in accordance with the laws of India.

M/s ITI Ltd. has sole rights for the feasibility report submitted by M/s ----- for its use with another successful bidder for next Phase (if any). If there is any conflict between earlier clauses and this clause, then this clause shall prevail.

That in case of any dispute or differences, breach & violation relating to the terms of the agreement. The said matter or dispute, difference shall be referred to sole arbitration of Chairman ITI Ltd or any other person appointed by him. That the award of the arbitrator shall be final and binding on both parties. In the vent of such arbitrator to whom the matter is originally referred to is being transferred or vacates his office on resignation or otherwise or refuses to do work or neglecting his work or being unable to act as Arbitrator for any reasons whatsoever, the Chairman ITI Ltd shall appoint another person to act as Arbitrator in place of outgoing Arbitrator and the person so appointed shall be entitled to proceed further with the reference from the stage at which it was left by his predecessor. The M/s ----- will have No Objection in any such appointment, that arbitrator

so appointed is employee of ITI Ltd. The said Arbitrator shall act under the Provisions of the Arbitrator and Conciliation Act, 1996 or any statutory modifications or re-enactment there of any rules made thereof.

This Agreement and Exhibit A attached hereto constitutes the entire agreement of the parties with respect to the parties' respective obligations in connection with Information disclosed hereunder and supersedes all prior oral and written agreements and discussions with respect thereto. The parties can amend or modify this agreement only by a writing duly executed by their respective authorized representatives. Neither party shall assign this Agreement without first securing the other Party's written consent.

This Agreement will remain in effect for one year from the date of the last disclosure of Confidential Information., at which time it will terminate, unless extended by the disclosing party in writing.

IN WITNESS WHEREOF, the parties hereto have executed this Agreement by Their duly authorized

officers or representatives.

(M/s-----)

Signature  
Name  
Designation  
ITI Ltd RFP No.  
Exhibit A

(M/s ITI Ltd.)

Signature:  
Name:  
Designation:

Business Purpose:

Confidential Information of M/s. ITI Ltd. w.r.t RFP No. \_\_\_\_\_

All sites and their related information.

All information shared in oral or in written form by ITI Ltd. with M/s -----

Information downloaded or taken in physical form shall be returned/destroyed after use not copied.

ITI Ltd: .....

Sign & Stamp

M/s -----(Bidder)

Sign & Stamp

**DECLARATION THAT THE BIDDER HAS NOT BEEN BLACKLISTED/DEBARRED  
(On Rs. 100/- Stamp paper)**

Letter No. \_\_\_\_\_

Dated: \_\_\_\_\_

**Subject: - Declaration Letter for Non-Blacklisting of the Bidder.**

Sir/Madam,

This is to notify you that our Company/ Partnership <Name>intends to submit a proposal in response to the RFP No.:....., we also declare that our Company/ Partnership is **not black-listed/ debarred by any PSU or State/UT or Central Government in India as on <the date of the submission of bid>.**

Sincerely,

(Signature of authorized person) Name:

Designation:

**Note:** If the Company/ Partnership has been blacklisted/debarred by any PSU or State/UT or Central Government in India in past and now the order has been revoked or period finished, then bidder should furnish details of such cases.

DECLARATION OF BIDDERS

FROM,

TO

1. I/We .....have read the conditions of the tender and tender documents attached here to and agree to abide by such conditions. I/We offer to do..... at the rates quoted in the attached schedule to complete the works on or before the dates mentioned in the schedule for completion of works.
2. I/We further agree to sign an agreement, bind to abide by the general conditions of the contract, and to carry out all works according to the specifications laid down in the tender papers. I/We hereby pay the earnest money of .....by demand draft/banker’s cheque. I/We bind myself/ ourselves to deposit the security deposit [Performance security] as prescribed within 15 days after receiving the notice that the contract has been awarded to me/us failing which I/We have no objection to the forfeiture of the earnest money in full; otherwise said earnest money shall be retained by the said company towards security deposit as specified in the conditions. I/We further bind myself /ourselves to execute the Tender document and to commence the work with 15 days after issue of the Purchase order in writing as aforesaid failing I/We agree to the company forfeiting the earnest money and security deposit deposited with them. The accepting authority shall also be at liberty to cancel the acceptance of the tender if I/We fails to deposit the security amount as specified or to execute an agreement or to start work as stipulated in the tender documents.
3. I/We hereby enclose a declaration of my/our experience of execution of works of similar nature and magnitude carried out by me/us in the prescribed Performa, and also the income tax and sales tax clearance certificates.
4. The offer shall remain open for acceptance by the Accepting Authority for a **period of 6 months** from the date of opening of the tender. **[180 days]**

Date:

Signature of bidder  
with the seal of the firm

witness.....

.... (Name in block letters)

Power of attorney in case the tender is signed by the authorized nominee must be enclosed. Address:

Occupation:

**POWER OF ATTORNEY**

Know by all men by these presents, We (Name of the Bidder and address of their registered office) do hereby constitute, appoint and authorize Mr. / Ms (name and residential address of Power of attorney holder) who is presently employed with us and holding the position of as our Attorney, to do in our name

and on our behalf, all such acts, deeds and things necessary in connect ion with or incidental to our Proposal for “Request for Proposals for “ .....Bid Number: < > including signing and

submission of all documents and providing information / responses to the Department, representing us in all matters before Department, and generally dealing with the Department in all matters in connection with our Proposal for the said Project.

We hereby agree to ratify all acts, deeds and things lawfully done by our said Attorney pursuant to this Power of Attorney and that all acts, deeds and things done by our aforesaid Attorney shall and shall always be deemed to have been done by us.

For,

Name:

Designation:

Date & Time:

Seal:

Business Address:

Accepted,

(Authorized Signatory)

(Name, Title and Address of the Attorney)

**Note:** The mode of execution of the Power of Attorney should be in accordance with the procedure, if any, laid down by the applicable law and the charter documents of the executant(s) and when it is so required the same should be under common seal affixed in accordance with the required procedure.

- The Power of Attorney shall be provided on Rs.100/- stamp paper.
- The Power of Attorney should be supported by a duly authorized resolution of the Board of Directors of the company Bidder authorizing the person who is issuing this power of attorney on behalf of the Bidder.

**EMD BANK GUARANTEE PROFORMA**

1. As agreed under the relevant terms and conditions of Enquiry Ref \_\_\_\_\_ dt \_\_\_\_ (hereinafter called the said Enquiry) between M/s. ITI Ltd., NS Unit, Dooravani Nagar, Begaluru-560016, India. (Hereinafter called the Purchaser) and M/s. \_\_\_\_\_ (hereinafter called the Bidder) for supply of \_\_\_\_\_, the Bidder hereby agrees to furnish EMD against supply performance by way of an irrevocable Bank Guarantee for Rs. \_\_\_\_\_ (Rupees. \_\_\_\_\_). We \_\_\_\_\_ (indicate the name of Bank) (hereinafter referred to as 'THE BANK' at the request of the Bidder do hereby undertake to pay to the Purchaser, an amount not exceeding Rs. \_\_\_\_\_ (Rupees. \_\_\_\_\_) against any loss or damage caused to or suffered or would be caused to or suffered by the Purchaser, by reasons or breach by the said Bidder of any of the terms or conditions contained in the said Enquiry.
  
2. We \_\_\_\_\_ (indicate the name of the Bank) do hereby undertake to pay the amount due and payable under this Guarantee without any demur, merely on a demand from the Purchaser stating that the amount claimed is due by way of loss or damage caused to or would be caused to or suffered by the Purchaser, by reason of breach by the said Bidder of any of the terms and conditions contained in the said Enquiry or by reason of the Bidder's failure to perform the said Enquiry. Any such demand made on the bank shall be conclusive as regards the amount due and payable by the Bank under this Guarantee shall be restricted to an amount not exceeding Rs. \_\_\_\_\_ (Rupees. \_\_\_\_\_).
  
3. The Bank further agrees that the Purchaser shall be the sole judge as to whether the said Bidder has committed any breach or breaches of any of the terms and conditions of the contract and the extent of loss, damage, costs, charges and expenses caused to or suffered by or that may be caused to or suffered by the Purchaser on account thereof, and the decision of the Purchaser that the said Bidder has committed such breach or breaches and as to the amount or amounts of loss, damage costs, charges and expenses caused to or suffered by or that may be caused to or suffered by the Purchaser from time to time shall be conclusive, final and binding on the Bank.
  
4. We undertake to pay to the Purchaser, any money so demanded notwithstanding any dispute or disputes raised by the Bidder in any suit or proceedings pending before any Court or Tribunal relating thereto our liability under this present being absolute and unequivocal.
  
5. It shall not be necessary for the Purchaser to proceed against the Bidder before proceeding against the Bank and the Guarantee herein contained shall be enforceable against the Bank notwithstanding any security which the Purchaser may have obtained or obtains from the Bidder.

6. We \_\_\_\_\_(indicate the name of Bank) further agree with the Purchaser, that the Purchaser shall have the fullest liberty without our consent and without effecting in any manner our obligation hereunder to vary any of the terms and conditions of the said Enquiry or to extend time of performance by the said Bidder from time to time or to postpone for any time or from to time any of the powers exercisable by the Purchaser against the said Bidder and to forbear or enforce any of the terms and conditions relating to the said Enquiry and we shall not be relieved from our liability by reasons of any such variation, or extension being granted to said Bidder or for any forbearance, act or omission on the part of the Purchaser or any indulgence by the Purchaser, to the said Bidder or by any such matter or thing whatsoever which under the law relating to sureties would, but for this provision, have effect of so relieving us.
7. This Guarantee will not be discharged due to the change in the constitution of the Bank or the Bidder.
8. We \_\_\_\_\_ (indicate the name of Bank) undertake not to revoke this Guarantee during its currency except with the previous written consent of the Purchaser, in writing.
9. Notwithstanding anything contained in the foregoing clauses, our liability under this guarantee is restricted to Rs. \_\_\_\_\_(Rupees. \_\_\_\_\_) and our guarantee shall remain in force until \_\_\_\_\_(Date of expiry of Bid validity). Unless a demand is made against us to enforce a claim under this guarantee within three months from the date of expiry of Bid validity, all your rights under this guarantee shall be forfeited and we shall be relieved and discharged from all liability hereunder.

PLACE:

DATE :

For  
\_\_\_\_\_(indicate the  
name of Bank)

**UNDERTAKING REGARDING LITIGATION/ ARBITRATION**

To,  
M/s ITI Limited  
NSU, Bangalore-  
560016

We hereby confirm and declare that

- a. We, M/s-----, does not have any litigation / Arbitration History with any Government department/ Public Sector Undertaking/ Private Sector/ or any other agency for which we have Executed/ Undertaken the works/ Services during the last      years.
  
- b. There is no litigation pending or, to the best of such Party's knowledge, threatened to which it or any of its Associates is a party that presently affects or which would have a material adverse effect on the financial condition or prospects or business of such Party in the fulfilment of its obligations under this Agreement.

For-----

Authorised Signatory

Date:

Place

**BANK GUARANTEE PROFORMA**

1. As agreed under the relevant terms and conditions of Purchase Order Ref ..... dt ..... (hereinafter called the said Purchase Order) between M/s. ITI Ltd.,  
NS Unit, Dooravaninagar, Bangalore-560 016, India. (Hereinafter called the purchaser) and M/s.  
..... (Hereinafter called the supplier) for supply of  
..... the supplier hereby agrees to furnish a security Deposit against supply performance by way of an irrevocable Bank Guarantee for Rs..... (Rupees.....) We..... (indicate the name of Bank)  
(hereinafter referred to as 'THE BANK' at the request of the supplier do hereby undertake to pay to the purchaser, an amount not exceeding Rs. .... (Rupees.....) against any loss or damage caused to or suffered or would be caused to or suffered by the Purchaser, by reasons or breach by the said supplier of any of the terms or conditions contained in the said Purchase Order.
2. We..... (indicate the name of the Bank) do hereby undertake to pay the amount due and payable  
under this Guarantee without any demur, merely on a demand from the purchaser stating that the amount claimed is due by way of loss or damage caused to or would be caused to or suffered by the purchaser, by reason of breach by the said supplier of any of the terms and conditions contained in the said Purchase Order or by reason of the supplier's failure to perform the said Purchase Order. Any such demand made on the bank shall be conclusive as regards the amount due and payable by the Bank under this Guarantee shall be restricted to an amount not exceeding Rs..... (Rupees.....)
3. The Bank further agrees that the Purchaser shall be the sole judge as to whether the said Supplier has committed any breach or breaches of any of the terms and conditions of the contract and the extent of loss, damage, costs, charges and expenses caused to or suffered by or that may be caused to or suffered by the Purchaser on account thereof, and the decision of the Purchaser that the said Supplier has committed such breach or breaches and as to the amount or amounts of loss, damage costs, charges and expenses caused to or suffered by or that may be caused to or suffered by the Purchaser from time to time shall be conclusive, final and binding on the Bank.
4. We undertake to pay to the Purchaser, any money so demanded notwithstanding any dispute or disputes raised by the Supplier in any suit or proceedings pending before any Court or Tribunal relating thereto our liability under this present being absolute and unequivocal.
5. It shall not be necessary for the Purchaser to proceed against the Supplier before proceeding against the Bank and the Guarantee herein contained shall be enforceable against the Bank notwithstanding any security which the Purchaser may have obtained or obtains from the Supplier.

6. We ..... (indicate the name of Bank) further agree with the Purchaser, that the Purchaser shall have the fullest liberty without our consent and without effecting in any manner our obligation hereunder to vary any of the terms and conditions of the said Purchase Order or to extend time of performance by the said Supplier from time to time or to postpone for any time or from to time any of the powers exercisable by the Purchaser against the said Supplier and to forbear or enforce any of the terms and conditions relating to the said Purchase Order and we shall not be relieved from our liability by reasons of any such variation, or extension being granted to said Supplier or for any forbearance, act or omission on the part of the Purchaser or any indulgence by the Purchaser, to the said Supplier or by any such matter or thing whatsoever which under the law relating to sureties would, but for this provision, have effect of so relieving us.
7. This Guarantee will not be discharged due to the change in the constitution of the Bank or the Supplier.
8. We ..... (indicate the name of Bank) undertake not to revoke this Guarantee during its currency except with the previous written consent of the Purchaser, in writing.
9. Notwithstanding anything contained in the foregoing clauses, our liability under this guarantee is restricted to Rs.....(Rupees.....) and our guarantee shall remain in force until ..... (Date of expiry of warranty period + 60 Days). Unless a demand is made against us to enforce a claim under this guarantee within twelve months from the date of expiry of warranty period, all your rights under this guarantee shall be forfeited and we shall be relieved and discharged from all liability hereunder.

DATE:

For..... (indicate the name of Bank)

PLACE:

UN PRICE BID

Serial No.	Item Description	Unit	Quantity	Unit cost (INR) (excl. tax)	Total Cost (INR) (Excl. tax)	% of GST for corresponding HSN Code	Total GST in INR	Total cost (Inclusive Of GST) (In INR)	HSN/SAC suggested by BSNL CO Taxation cell
A	B	C	D	E	F=D*E	G	H	I=F+H	J
<b>VENDOR NAME</b>									
1	Physical Survey, BoQ submission, approval of route plan and BoQ, ABD preparation, Excavation of trenches (in all types of soil strata) for PLB pipe laying (either Open Trench/HDD), Backfilling, Reinstatement and Compaction after laying of HDPE pipe, Pulling/laying/blowing of optical Fibre Cable inside laid PLB pipe, splicing and jointing of Optical Fibre Cable including support to GIS partner for preparing the As Built Diagram (ABD) of constructed OFC Route and Acceptance Testing, commissioning and makeover of the routes. The work also includes road/bridge crossing, laying of PLB inside DWC/RCC pipe, wherever required. Commissioning of 24 F optical fibre connectivity from the Block PoP to GP and termination at GP. The cost shall include supply and fixing of joint chamber, manhole, splicing, Fixing, painting and sign writing of Route /Joint Indicators, and end to end testing of dark and lit fibre per GP. For Underground OFC laying, as per the Engineering Instruction issued by BSNL (Payment shall be made as per Trenching length only)	RKM	1025						
2	Physical Survey, BoQ submission, approval of route plan and BoQ, ABD preparation, Excavation of trenches (in all types of soil strata) for PLB pipe laying (either Open Trench/HDD), Backfilling, Reinstatement and Compaction after laying of HDPE pipe, Pulling/laying/blowing of 48F ribbon type armoured optical Fibre Cable inside laid PLB pipe, splicing and jointing of Optical Fibre Cable including support to GIS partner for preparing the As Built Diagram (ABD) of constructed OFC Route and Acceptance Testing, commissioning and makeover of the routes. The work also includes road/bridge crossing, laying of PLB inside DWC/RCC pipe, wherever required. Commissioning of 48 F Ribbon Armoured optical fibre connectivity from the Block PoP to GP and termination at GP. The cost shall include supply and fixing of joint chamber, manhole, splicing, Fixing, painting and sign writing of Route /Joint Indicators, and end to end testing of dark and lit fibre per GP. For Underground OFC laying, as per the Engineering Instruction issued by BSNL (Payment shall be made as per Trenching length only)	RKM	200						
3	Physical Survey, BoQ submission, approval of route plan and BoQ, ABD preparation, Stringing / Laying of ADSS 24 core of optical Fibre Cable on existing Power Poles or new Poles wherever required, splicing and jointing of Optical Fibre Cable including support to GIS partner for preparing the As Built Diagram (ABD) of constructed OFC Route and Acceptance Testing, commissioning and makeover of the routes. Commissioning of 24 core ADSS optical fibre connectivity from the Block PoP to GP. The cost shall include supply and fixing of installation accessories, splicing, Fixing, painting and sign writing of Route /Joint Indicators, termination at FTB/FDMS and all the relevant Pole accessories etc. and end to end testing of dark and lit fibre per GP. For Overhead laying, as per the Engineering Instruction issued by BSNL. Payment shall be made as per point-to-point hop length only, Not based on fiber length.	RKM	50						
4	Supply & Erection of GI pole as mentioned in Technical Specifications	Nos	500						
5	Stringing / Laying of 6 F aerial drop OFC Cable on existing Electricity Poles or new wooden or GI Poles wherever required, and termination of 6F in the FDB. Acceptance Testing, commissioning of the routes from the GP to village. The cost shall include fixing of installation accessories, termination of 6F in FTB and all the relevant Pole accessories etc. and end to end testing of all 6 fibers. For Overhead laying, as per the Engineering Instruction issued by BSNL. Payment shall be made as per point-to-point hop length only, Not based on fiber length.	RKM	4,607						
6	Supply, installation of Joint Chamber, testing and splicing 24 F for Dark Fibre Provisioning and/or attending OFC fault for the first time in a joint as per TEC GR/ E.I. for restoration of existing network	Per splicing location	100						
<b>Total cost in INR</b>									

Note:  
 1. Relevant Columns to be filled with PERCENTAGE/NUMERICAL values ONLY. Quoted price will include Packaging/Forwarding Charges (If Any) and Freight/Insurance Charges (If Any)  
 2. BIDDER has to quote for all the items.  
 3. Evaluation will be done based on the TOTAL VALUE

Signature of the bidder with Seal



हिंदी केवल एक भाषा नहीं बल्कि हमारी राष्ट्रीय पहचान है।



### आईटीआई लिमिटेड

नेटवर्क सिस्टम्स युनिट - वित्त  
दूरवाणीनगर, बैंगलूर - 560 016, भारत  
फोन : +91 (80) 2566 0503  
: +91 (80) 2565 1714  
ई-मेल : cfm\_nsu@itiltld.co.in  
वेबसाइट : www.itiltld.in  
CIN No. : L32202KA1950GOI000640

### ITI LIMITED

Network Systems Unit - Finance  
Dooravaninagar  
Bengaluru-560 016, India.  
Tel : +91 (80) 2566 0503  
: +91 (80) 2565 1714  
E-mail : cfm\_nsu@itiltld.co.in  
Website : www.itiltld.in  
GSTIN No. : 29AAACI4625C2ZU

### RTGS/NEFT/ECS Mandate Form

1	Name of the Beneficiary	M/s ITI Limited - Network Systems Unit
2	Beneficiary Address	Regd. & Corporate Office, ITI Bhavan, Dooravaninagar, Bangalore 560016
3	Bank Account No.	10637729843
4	IFSC Code	SBIN0009077
5	a) Bank Name	State Bank of India
	b) Branch Name	Industrial Finance Branch
	c) Branch Address	Residency Road, Bangalore - 560025
6	Type of Account	CC Account
7	PAN No.	AAACI4625C
8	Bank MICR Code	560002059

I do hereby declare that the particulars given above are correct and complete.  
If the transaction is delayed or not effected at all for reasons of incomplete or  
incorrect information, the purchaser will not be responsible.

Date: 12/06/2024

*Kanchana*  
Authorised Signatories  
**KANCHANA**  
Dy. Finance Manager  
Network Systems Unit,  
ITI Limited, Dooravaninagar,  
Bangalore - 560016

Certified that the particulars furnished above are correct as per our records.

For STATE BANK OF INDIA  
*Kamini*  
Manager  
S.B.I. Branch Office, Bangalore - 560 025

Date:

Signature of Bank Manager  
With Bank Seal

पंजीकृत एवं निगमित कार्यालय : आईटीआई भवन, दूरवाणीनगर, बैंगलूर - 560016, भारत फोन : +91 (080) 2561 4466, फैक्स : +91 (080) 2561 7525  
Registered & Corporate Office : ITI Bhavan, Dooravaninagar, Bengaluru - 560016, India Phone: +91(080) 2561 4466, Fax: +91(080) 2561 7525  
TIN : 29980058837 GSTIN : 29AAACI4625C2ZU CIN : L32202KA1950GOI000640 Visit our Website : www.itiltld.in

**ADDITIONAL INSTRUCTIONS FOR BIDDERS**

The bidders are required to submit soft copies of their bid electronically on the e-Wizard Portal using valid Digital Signature Certificates. Below mentioned instructions are meant to guide the bidders for registration on the e-Wizard Portal, prepare their bids in accordance with the requirements and submit their bids online on the e-Wizard Portal. For more information, bidders may visit the Portal (<https://itilimited.ewizard.in>)

**1. REGISTRATION PROCESS ON ONLINE PORTAL**

- a) Bidders to enroll on the e-Procurement module of the portal <https://itilimited.ewizard.in> by clicking on the link "Bidder Enrolment".
- b) The bidders to choose a unique username and assign a password for their accounts. Bidders are advised to register their valid email address and mobile numbers as part of the registration process. This would be used for any communication from the e-Wizard Portal.
- c) Bidders to register upon enrolment, with their valid Digital Signature Certificate (Class III Certificates with signing and Encryption key) issued by any Certifying Authority recognized by CCA India with their profile.
- d) Only one valid DSC should be registered by a bidder. Please note that the bidders are responsible to ensure that they do not lend their DSCs to others which may lead to misuse.
- e) Bidder then logs in to the site through the secured log-in by entering their user ID/password and the password of the DSC / e-Token.
- f) After registration send mail to Helpdesk: [helpdeskeuniwizarde@gmail.com](mailto:helpdeskeuniwizarde@gmail.com) for Account activation.
- g) As per portal norms Registration Fee will be applicable.

**2. TENDER DOCUMENTS SEARCH**

- a) Various built-in options are available in the e-Wizard Portal like Department name, Tender category, estimated value, Date, other keywords, etc. to search for a tender published on the Online Portal.
- b) Once the bidders have selected the tenders they are interested in; they may download the required documents/tender schedules. These tenders can be moved to the respective 'Interested tenders' folder.
- c) The bidder should make a note of the unique Tender No assigned to each tender, in case they want to obtain any clarification/help from the Helpdesk.

**3. BID PREPARATION**

- a) Bidder should take into account any corrigendum published on the tender document before submitting their bids.
- b) Please go through the tender advertisement and the tender document carefully to understand the documents required to be submitted as part of the bid.
- c) Please note the number of covers in which the bid documents have to be submitted, the number of documents - including the names and content of each of the document that needs to be submitted. Any deviations from these may lead to rejection of the bid.
- d) Bidder, in advance, should get ready the bid documents to be submitted as indicated in the tender document/schedule and generally, they can be in PDF/XLSX/PNG, etc. formats.

#### **4. BID SUBMISSION**

- a) Bidder to log into the site well in advance for bid submission so that he/she uploads the bid in time i.e. on or before the bid submission time. Bidder will be responsible for any delay due to other issues.
- b) The bidder to digitally sign and upload the required bid documents one by one as indicated in the tender document.
- c) Bidders to note that they should necessarily submit their financial bids in the prescribed format given by department and no other format is acceptable.
- d) The server time (which is displayed on the bidders' dashboard) will be considered as the standard time for referencing the deadlines for submission of the bids by the bidders, the opening of bids, etc. The bidders should follow this time during bid submission.
- e) All the documents being submitted by the bidders would be encrypted using PKI encryption techniques to ensure the secrecy of the data, which cannot be viewed by unauthorized persons until the time of bid opening.
- f) The uploaded tender documents become readable only after the tender opening by the authorized bid openers.
- g) Upon the successful and timely submission of bids, the portal will give a successful bid submission message & a bid summary will be displayed with the bid no. and the date & time of submission of the bid with all other relevant details.
- h) The off-line tender shall not be accepted and no request in this regard will be entertained whatsoever.
- i) As per portal norms Tender Processing Fee will be applicable.

#### **5. AMENDMENT OF BID DOCUMENT**

At any time prior to the deadline for submission of proposals, the department reserve the right to add/modify/delete any portion of this document by the issuance of a Corrigendum, which would be published on the website and will also be made available to the all the Bidder who has been issued the tender document. The Corrigendum shall be binding on all bidders and will form part of the bid documents.

#### **6. ASSISTANCE TO BIDDERS**

- a) Any queries relating to the tender document and the terms and conditions contained therein should be addressed to the Tender Inviting Authority for a tender or the relevant contact person indicated in the tender.
- b) Any queries relating to the process of online bid submission or queries relating to e- Wizard Portal, in general, may be directed to the 24x7 e-Wizard Helpdesk.
- c) The tender inviting authority has the right to cancel this e-tender or extend the due date of receipt of the bid(s).
- d) The bid should be submitted through e-Wizard portal (<https://itilimited.ewizard.in> ) only.
- e) All payments should be done through e-Wizard Payment gateway.

Serial No.	Item Description	REF NO: NSU 5G 51 Y/ II		PRICE BID FORMAT			Annexure C			
		Unit	Quantity	Unit cost (INR) (Excl. tax)	Total Cost (INR) (Excl. tax)	% of GST for corresponding HSN Code	Total GST in INR	Total cost (Inclusive of GST) (In INR)	HSN/SAC suggested by BSNL CO Taxation cell	
A	B	C	D	E	F=D*E	G	H	I=F+H	J	
VENDOR NAME		ZONE-2								
1	Physical Survey, BoQ submission, approval of route plan and BoQ, ABD preparation, Excavation of trenches (in all types of soil strata) for PLB pipe laying (either Open Trench/HDD), Backfilling, Reinstatement and Compaction after laying of HDPE pipe, Pulling/laying/blowing of optical Fibre Cable inside laid PLB pipe, splicing and jointing of optical Fibre Cable including support to GIS partner for preparing the As Built Diagram (ABD) of constructed OFC Route and Acceptance Testing, commissioning and makeover of the routes. The work also includes road/bridge crossing, laying of PLB inside DWV/RCC pipe, wherever required. Commissioning of 24 F optical fibre connectivity from the Block PoP to GP and termination at GP. The cost shall include supply and fixing of joint chamber, manhole, splicing, Fixing, painting and sign writing of Route /Joint Indicators, and end to end testing of dark and lit fibre per GP. For Underground OFC laying, as per the Engineering Instruction issued by BSNL (Payment shall be made as per Trenching length only)	RKM	1025							
2	Physical Survey, BoQ submission, approval of route plan and BoQ, ABD preparation, Excavation of trenches (in all types of soil strata) for PLB pipe laying (either Open Trench/HDD), Backfilling, Reinstatement and Compaction after laying of HDPE pipe, Pulling/laying/blowing of 48F ribbon type armoured optical Fibre Cable inside laid PLB pipe, splicing and jointing of optical Fibre Cable including support to GIS partner for preparing the As Built Diagram (ABD) of constructed OFC Route and Acceptance Testing, commissioning and makeover of the routes. The work also includes road/bridge crossing, laying of PLB inside DWV/RCC pipe, wherever required. Commissioning of 48 F Ribbon Armoured optical fibre connectivity from the Block PoP to GP and termination at GP. The cost shall include supply and fixing of joint chamber, manhole, splicing, Fixing, painting and sign writing of Route /Joint Indicators, and end to end testing of dark and lit fibre per GP. For Underground OFC laying, as per the Engineering Instruction issued by BSNL (Payment shall be made as per Trenching length only)	RKM	200							
3	Physical Survey, BoQ submission, approval of route plan and BoQ, ABD preparation, Stringing / Laying of ADSS 24 core of optical Fibre Cable on existing Power Poles or new Poles wherever required, splicing and jointing of Optical Fibre Cable including support to GIS partner for preparing the As Built Diagram (ABD) of constructed OFC route and Acceptance Testing, commissioning and makeover of the routes. Commissioning of 24 core ADSS optical fibre connectivity from the Block PoP to GP. The cost shall include supply and fixing of installation accessories, splicing, Fixing, painting and sign writing of Route /Joint Indicators, termination at FTB/FDMS and all the relevant Pole accessories etc. and end to end testing of dark and lit fibre per GP. For Overhead laying, as per the Engineering Instruction issued by BSNL. Payment shall be made as per point-to-point hop length only, Not based on fiber length.	RKM	50							
4	Supply & Erection of GI pole as mentioned in Technical Specifications	Nos	500							
5	Stringing / Laying of 6 F aerial drop OFC Cable on existing Electricity Poles or new wooden or GI Poles wherever required, and termination of 6F in the FDB. Acceptance Testing, commissioning of the routes from the GP to village. The cost shall include fixing of installation accessories, termination of 6F in FTB and all the relevant Pole accessories etc. and end to end testing of all 6 fibers. For Overhead laying, as per the Engineering Instruction issued by BSNL. Payment shall be made as per point-to-point hop length only, Not based on fiber length.	RKM	4,607							
6	Supply, installation of Joint Chamber, testing and splicing 24 F for Dark Fibre Provisioning and/or attending OFC fault for the first time in a joint as per TEC GR/ E.L for restoration of existing network	Per splicing location	100							
Total cost in INR										

Note:

1. Relevant Columns to be filled with PERCENTAGE/NUMERICAL values ONLY. Quoted price will include Packaging/Forwarding Charges (If Any) and Freight/Insurance Charges (If Any)
2. BIDDERS has to quote for all the items.
3. Evaluation will be done based on the TOTAL VALUE

Handwritten signature and date: 06/05/26