



ITI LIMITED MANKAPUR , DISTT. GONDA - 271308 (U.P.) INDIA

TENDER ID NO. : C570579

Date: 21.01.2021

DUE Date: 03.02.2021 (11:00 Hrs IST)

Tender Opening Date 03 . 02 . 2021 (11:30 Hrs IST)

**Venue of Tender opening :- " COMPUTER DIVISION " ITI Ltd., Mankapur
M/ s -**

SUB: Tender enquiry for supply of Castor Wheel for UVDS as mentioned below:

Dear Sir,

Please quote your most competitive rates and best delivery terms for the following Item on the terms & conditions as given below : -

SI no.	ITEM CODE	DESCRIPTION	QTY.	TECH. SPEC.
1	MCUVDS017	TUBE LIGHT HOLDER AS PER ENCLOSED DRAWING.	1200 Nos.	

1a. Offers must be submitted in sealed envelope to MANAGER (TENDER CELL), COMPUTER DIVISION, ITI LTD., MANKAPUR - 271 308, GONDA, U.P. (INDIA) on or before 11.00Hrs. (IST) of the due date.

1b. Important Notes: Incase of tender are being submitted through e-mail, following guidelines must be followed.

(I) The e- mail quotations/offers may be submitted as attachment (s) at e-mail – ID newtender_mkp@itilttd.co.in . The attachment (s) must be .pdf/.doc/.xls/.jpg/.tif type file .

(II) No copy (CC) of quotations/offers should be sent to any other e-mail-ID of ITI Limited.

(III) The subject line of the- mail for offer/quotations must contain Tender ID No C570579 and Due date 03.02.2021.

(IV) Kindly contact at mmcomp_mkp@itilttd.co.in for any clarification.

(V) Offer shall not be considered in case of violation of above instruction.

Incuse of tender are being submitted through e-mail, post confirmation hard copy must be sent to MANAGER (TENDER CELL).

2. The detailed General Terms and Conditions for submission of Tender- Inland (which is an integral part of this tender enquiry) can be downloaded from our website: www.itilttd-india.com Point to point compliance of detailed General Terms & Conditions for submission of tender is must.

Otherwise, it will be presumed that the same are acceptable to the bidder.

3. Delivery Required: - 600 Nos. by 15.02.2021 & 600 Nos. by 15.03.2021.

4.Validity of the offer: - 180 Days.

5.Interested bidders may participate in tender opening.

6. Late offers received after due date will not be considered.

7. Please mentions your GSTIN no. / TIN and HSN code / Commodity code in your quotation .

You are requested to submit your quotation on or before due date positively.

K L YADAV
AMM – C&C
ITI LTD, MANKAPUR-271308
DIST: - GONDA (U.P.), INDIA
Ph: 05265-274225
E-mail: mmcomp_mkp@itilttd.co.in
Fax no : (91) 5265- 230179, 230199.

MTD

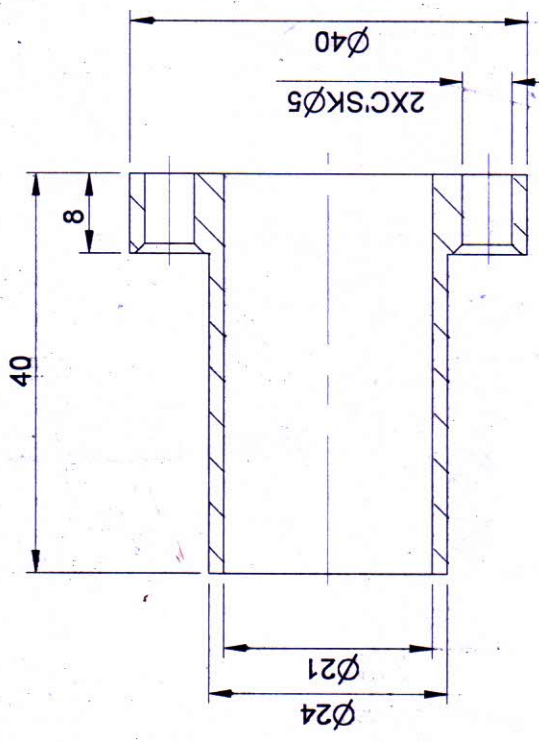
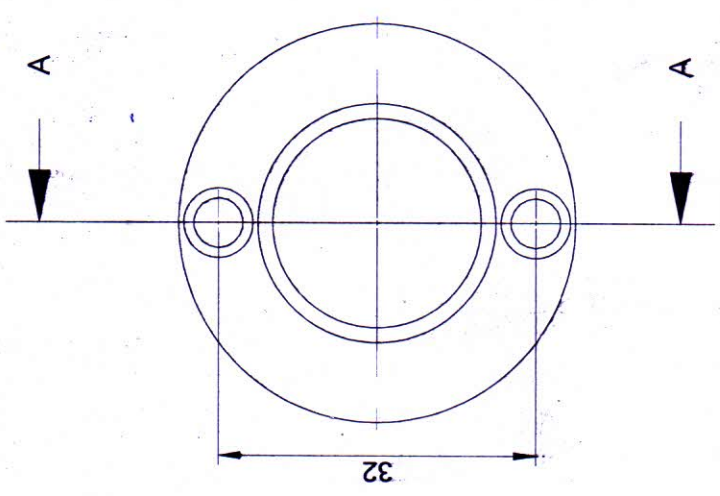

SECTION - 'A-A'

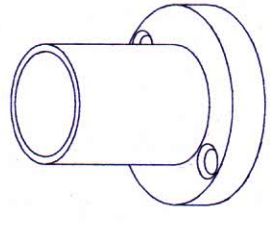

SECURITY CONTROLLED COPY
 Of No. DRG. D1801-1830
 Signature: [Signature]
 of Issuing Authority

MASTER COPY

GENERAL TOL. : ± 0.2 mm.

MATERIAL - NYLON / TEFLON
 QTY. 12 NOS.

TUBE HOLDER (DRDO)

2020	DATE	SIGN.	SUPERSEDED BY	RELACES
DRN	18/09/20	[Signature]		
CKD.	18/09/20	[Signature]	MCUVDS017	
APPD.	18/09/20	[Signature]	MCUVDS001A	
ISSUE DATE	18/09/20	SIGN.	ITEM CODE NO.:	MCUVDS017
			TO BE USED ON:	MCUVDS001A
			REF.	Sheet OF Sheets
			DRG. NO.	M 3 3 7 9 0 8 3

MODIFICATIONS

ITLTD. MANIPUR
 COMPONENT-TOOL DESIGN

1 | 2 | 3 | 4 | 5 | 6 | 7 | 8

TERMS AND CONDITIONS FOR SUBMISSION OF TENDER -INLAND

1.SUBMISSION OF TENDERS:

- 1.a. This is only an enquiry to quote and not an order. This TENDER ENQUIRY is not transferable.
b. Tenders may be submitted in a sealed envelop super scribed with our Tender ID no & due date on the face of the envelope and should be addressed to:-

**MANAGER (TENDER CELL)
COMPUTER DIVISION
ITI LTD., MANKAPUR - 271 308.
GONDA, UP.**

You may submit your offer through e-mail also. Ensure submission of **tender before 11.00 hrs. IST** on the due date. If tender are being sent through e-mail, post confirmation hard copy must be sent to Manager (Tender cell) – Computer division.

Incase of tender are being submitted through e-mail, following guidelines must be followed.

(I) The e- mail quotations/offers may be submitted as attachment (s) at e-mail – ID newtender_mkp@itiltd.co.in only. The attachment (s) must be .pdf/.doc/.xls/.jpg/.tif type file .

(II) No copy (CC) of quotations/offers should be sent to any other e-mail-ID of ITI Limited.

(III) The subject line of the- mail for offer/quotations must contain Tender ID No C570579 and Due date 03.02.2021.

- NOTE :** a. Offers should reach to Manager (Tender Cell)- Computer Division on or before the due date before 11.00 Hrs. IST of the due date.
b. Separate envelopes should be used for each enquiry/ Tender ID.
c. Offers should have commercial condition and technical details.
d. Your offer should be valid for a period of 180 days from the indicated due date of tender. This is most important. Longer validity is preferred.
e. Basic rate and applicable taxes/duties must be quoted distinctly and separately. Rate such as inclusive of taxes/duties are not acceptable. In case taxes and duties are not applicable, then the same should be spelt out clearly in the offer.

2. OPENING OF TENDERS:

Tenders against our Enquiries (Tender ID) shall be opened on Tender Opening Date **at 11:30 hrs. IST**. The Tender Opening Date is mentioned in covering letter of NIT. Venue of Tender opening will be “ COMPUTER DIVISION “ ITI Ltd., Mankapur. Interested bidders may participate in Tender opening.

3.LATE OFFERS :

Open tenders (not super-scribed with our tender ID No. and Due Date on the face of envelope) and/or tenders which are received late are liable for rejection.

NOTE :

- a. Send your quote well in advance of due date to avoid postal /courier delay.
b. If you are not in a position to quote , for any reason please communicate the same without fail to enable us to keep you on our vendor list.
c. Please indicate the ‘Sl. No.’ and Code/Description exactly as per our enquiry. Any substitute or alternate code quoted should be clearly stated. In case the item quoted is under obsolescence, the same may be indicated with best last date of P.O. and supply feasibility.

4.PRICES :

- a. ITI is planning to have long term tie up with limited vendors, who can keep up good quality, prompt delivery and lowest cost. Hence, you may quote in such a way that a long term relationship is possible.
b. Prices must be per unit and should be on **F.O.R. ITI Mankapur basis** only and inclusive of insurance charges. In such an event, while tabulating the offers, insurance is not to be reckoned and should include weatherproof packing adequate to withstand transshipment damages.

LOADING FOR INVISIBLE CHARGES:-

All qualified offers shall be compared on F.O.R. ITI Ltd, Mankapur basis. If your quote is other than F.O.R. ITI Mankapur(like EX-Works ,F.O.R. Place of dispatch etc) various expanses like packing & forwarding , freight , insurance, and interest charges against different payment / credit terms and mode of payment (like DD / Cheque / through Bank), Bank Charges, Non- Cenvatable portion of Taxes etc will be loaded for comparison of the offers to arrive at F.O.R. ITI Mankapur rate as per ITI norms.

- c. ITI, under normal circumstances, may not negotiate for the price. We may also short list up to three approved/qualified suppliers for ordering. Hence you are requested to quote your best price in the original quotation itself.
d. Any counter terms and conditions are not binding on us unless we agree to the same in writing.
e. In case of an order on you, the ordered rate should be firm till the completion of the order. In case where the market prices of your inputs are fluctuating too frequently, you shall clearly define price variation clause. Please note that any variation in price up to 5% due to variation in FE/statutory levies will be absorbed by the supplier. However, for variation beyond 5% due to variation in FE/ statutory levies, the burden of price increase/ advantages of price decrease will be shared equally between ITI and the supplier.
f. Vendors should deliver the material to designated stores, as per PO terms. Out station vendors can make use of their local representative / Courier Service/Surface transport on door delivery basis to deliver the material at designated stores. ITI LTD. will not take the responsibility of clearing the goods from the carriers go-down/office/railway station/airport etc.
g. In case of supply of imported items by local dealer’s proof of import should be provided. Prices quoted should indicate clearly the Cenvat relief (by way of C.V.D.), being passed on to ITI and supplier should furnish regular invoice indicating rate and amount of duty that is passed on which should be proportionate the material sold to ITI from the relevant imported consignment, covered under this appropriate Bill Of Entry.

5. STATUARY LEVIES:

- a. All applicable statutory levies under GST Act, should be separately indicated with the current rate applicable, otherwise rate quoted will be deemed as inclusive of taxes/levies. Vague terms like ‘As applicable at the time of supply’ should be avoided. Apart from Statutory levies, other charges like handling, P&F etc. will not be paid by us.
b. In case of your absorbing the GST portion, the same may be specified clearly in the quotation itself and not after the tender opening, which otherwise will be treated as post-tender correction and would disqualify your quote.
d. In case of GST modification, the same has to be intimated to ITI immediately.
c. Please ensure to indicate GSTIN number and commodity code in your quotation.

6. CENVAT/ITC RELIEF-

- (a) We are eligible to avail the ITC of GST paid on items procured for manufacturing telecommunication equipments under “CENVAT/ITC Relief Scheme. Hence “invoice cum delivery challan” in original for payment and transporter copy duly marked and authenticated is to be produced along with the consignment. In case of your failing to adhere to this instruction, no GST will be reimbursed by us.
(b) Invoices should be in the prescribed form and have all particulars as per the central GST Act and notifications as amended from time to time, particularly assessor code, range division, rate and amount of GST/duty debited and debit particulars.
(c) Agent/Distributor on whom an order is placed should also produce invoice cum delivery challan as per the procedure laid down by central GST Act and notification issued from time to time. They should get registered under GST Act, is being passed on.
(d) ECC number & GST registration number, range & collectorate/superintendent should be mentioned in your quotation.

7. TERMS OF PAYMENTS:

- a. Payment will be made for the accepted quantity within 60 days from the date of receipt of the material at our Stores.
- b. NO PAYMENT WILL BE MADE FOR THE REJECTED QUANTITY.
- c. The party may indicate whether they fall under the purview of MSMED Act 2006 and if so the certified copy of relevant registration certificate as a proof may be submitted along with your quotations. In case such certificate is not produced at the time of submission of quotation, Party will not be considered falling under this category.

8. INSPECTION:

- a. ITI reserves the right to restrict the ordering to 2 or 3 vendors who are capable of meeting the Quality, Delivery and Cost requirements. Preference will be given to the vendors with well-maintained and proven Quality Assurance Systems.
- b. We are planning to reduce inspection time with self-certification scheme for the vendors who keep up good quality leading to ship to stock systems.
- c. Inspection of the material at our works will be final. ITI reserves the right to inspect the material at any other standard testing center authorized by us.
- d. We or our representative including our customer may if required preliminarily inspect the product at vendor's premises. Such verification shall not absolve the vendor of the responsibility to provide the acceptable product nor shall preclude subsequent rejection during the final inspection at our works. It is the responsibility of every vendor to ensure that only the inspected materials conforming to our specifications / drawings/requirements are supplied.
- e. The supplies shall be from the latest batch of productions. Batch Number should be indicated on the components/packet/test certificate and accompanying delivery challan / test-certificate.
- f. Test Certificate / check list should accompany each supply. Consignments without test certificate are liable for rejection. Rejected material should be collected immediately (within 30 days) after our intimation by **giving two days prior notice for completing the necessary under GST Act**. You should make arrangement to collect the material either personally, OR through your authorized representatives. ITI does not take any responsibility to send the material back to you. After 90 days from the date of rejection intimation to you the material will be scrapped at your risk if not collected.

9. SAMPLES:

Those tenderers who have not supplied the material against any of our earlier orders, should submit FREE SAMPLES clearly indicating enquiry reference. Free samples along with your offer is preferable. In case of a Purchase Order on you, bulk supply should commence only after approval of samples.

10. WARRANTY:

Please note that we are an ISO 9001-2008 and ISO 14001-2004 accredited company. All our equipments / systems have a warranty of 18 months from the date of despatch to our customer. Hence the warranty of your products should be for a minimum period of 24 months from the date of supply. Within this warranty period, if any of your component/subsystem is found defective during our manufacturing process / system testing/installation and commissioning/operation of our equipment in the field, the same is to be replaced free of cost immediately by you.

11. GENERAL:

- a. We reserve the right to reject any or all offers and to order in full or part quantities thereof without assigning any reason whatsoever.
- b. *General guide lines for quantity distribution:- ITI at its discretion may order full qty. on one approved/qualified source or may distribute at L1 rate in between two / three approved/qualified vendors (in case of capacity restriction or to have alternate vendors to avoid dependency on single vendor) . The guiding ratio for distribution between two vendors would be 60:40 to 70:30. If distribution is done among three vendors, the guiding ratio would be 50:30: 20 but the quantity variation between L1 & L2 and L2& L3 will not be less than 5% . More than three approved/qualified vendors may also be considered for ordering in case of larger volume or capacity constraints. However, the final discretion of distributing the quantity solely lies with ITI depending upon the ITI requirement.*
- c. *Tabulations to arrive at F.O.R ITI Mankapur shall be done separately for individual item (not for a complete family) unless otherwise indicated specifically in NIT . And accordingly ordering shall be done on individual item basis.*
- d. *Canvassing by tenderers in any form including unsolicited letters against tenders submitted or post tender corrections shall render their tender liable for summarily rejection.*
- e. Successful tenderer only will be intimated by post through /letter of intent/firm order.
- f. ITI ,Mankapur is a ISO 14001:2004 certified company . Vendor must ensure to use eco-friendly materials in their processes and packagings. For handling , storage and transportation of materials, standard symbols must be used as per norms to satisfy ISO 14001:2004 . ISO 14001:2004 certified vendors should submit copy of certificate with quotation.

12. DELIVERY SCHEDULE:

- a. Please indicate minimum Lead time required, manufacturing capacity and the quantity that can be reserved for us.
- b. **Liquidated Damages Clause**
Time is the essence of contract and the materials, against an order arising out of this enquiry must be delivered by the supplier according to the delivery schedule indicated in the P.O. In case of any change, the supplier should inform us in advance and obtain our approval to the revised delivery schedule. Should the supplier fail to deliver the material or part thereof as per the delivery schedule , or any extension thereof, we shall be entitled at our option either to recover from the supplier, as penalty, a sum equivalent to 1/2% (half percent)per week for first four weeks and 1% per week thereafter for such delay or part thereof subject to a maximum of 5% of the contract price of the item delayed, or terminate the contract in respect of the balance supply so delayed and purchase materials elsewhere at the risk and cost of the defaulting supplier.

13. SECURITY DEPOSIT:

In case of an order on you, you will have to agree for an interest free security deposit sum of 5% of order value subject to a maximum of Rs.10 lacs by demand draft/ Bank Guarantee only. The same shall be forfeited in case you fail to execute the order to our satisfaction in all respects. This clause may be waived off in case of approved or established suppliers. However, the sole discretion lies with ITI.

14. LOCAL REPRESENTATION:

Please indicate your local representative's address, telephone no, Fax no. , e-mail address and the person to be contacted, in the offer.

15. TECHNICAL CATALOGUE:

In the event of any change in the technical catalogue, updated version may be sent to us immediately. It is essential that you simultaneously take up the same with approving authority and their approval copy sent to us.

16. Issue of 'C' Form' will be done on financial quarterly/year wise as per the statement to be furnished by you .

17. GOVERNING LAW:

All suits shall be instituted in a court of competent jurisdiction at MANKAPUR/GONDA and in case of arbitration; the Indian Arbitration Act 1996 is applicable.

18. CONSIDERATION OF INDIAN AGENT :-

- a. In a tender, either the Indian agent on behalf of the Principal/OEM or Principal/OEM itself can bid but both cannot bid simultaneously for the same item/product in the same tender.
- b. If an agent submits bid on behalf of the Principal/OEM , the same agent shall not submit a bid on behalf of another Principal/OEM in the same tender for the same item/product.