



BID DOCUMENT

E-TENDER FOR

- (1) LT Distribution Panel with Three Air Circuit breaker (ACB) at input and Two Air circuit Breaker (ACB) at output.**
- (2) LT Distribution Panel with One Air Circuit breaker (ACB) at input and Six(06) MCCB 's at output Air circuit Breaker (ACB) at output.**

Above items are required for augmentation of OFC Manufacturing Plant, as per Technical Specification(Annexure-1), General Requirement (Annexure-2) and General Specification for both type of panel mentioned along with BID DOCUMENT”.

TENDER NO. ESW18E1366CL, DATED 31.05.2021

DUE DATE: 14/06/2021 up to 15:00Hrs

Last date for Bid Clarification by bidders: - up to 04/06/2021

Respond to Bid Clarification by ITI: - 08/06/2021

Technical Bid Open:- 15/06/2021 @ 10:30 Hrs

ITI LIMITED

(A Government of India Undertaking)

Sultanpur Road, RAE BARELI-229010 (U.P)

Visit us at www.itiltd-india.com

ITI LIMITED

(A GOVT. OF INDIA UNDER TAKING)

DOORBHASH NAGAR , RAE BARELI -229010 (UP) INDIA

Tel.: 0535-2287565 , 2287387 FAX: 0535-2702106,

E-mail : rrpandey_rbl@itilttd.co.in

TENDER NO. ESW18E1366CL

(Please quote this in all correspondence)

TENDER DATE: 31/05/2021

DUE DATE : 14/06/2021

ON BEHALF OF ITI LIMITED, RAEBARELI. E-TENDERS ARE INVITED FROM THE ELIGIBLE BIDDERS AS PER BID DOCUMENT'S TERMS & CONDITIONS AT ANNEXURE- I & II, ITEM DESCRIPTION, QTY & DELIVERY SCHEDULE ETC AS GIVEN BELOW:

SN	Item Description	Qty. Reqd. (No.)	Delivery Reqd.
1-	LT Distribution Panel with Three Air Circuit breaker (ACB) at input and Two Air circuit Breaker (ACB) at output.	01	JUNE-2021
2-	LT Distribution Panel with One Air Circuit breaker (ACB) at input and Six (06) MCCB's at output Air circuit Breaker (ACB) at output.	02	

NOTE:

Technical Specifications & General Requirements for both the Items as per Annexure-1 and Annexure-2 enclosed.

Special Note:

1- E-tendering Instructions to Bidders:

Submission of Bids shall be only through e-tendering process on <https://itilttd.euniwizarde.com> which is mandatory for this Tender.

2- Tender Bidding Methodology:

Online Bid System-

Tender Type: Two bids i.e., Technical and Financial Bids shall be submitted by the bidder at the same time on the above mentioned tendering portal.

Note:

It is advised that all the documents to be submitted are kept scanned or converted to PDF format in a separate folder on your computer before online submission. BOQ (Excel Format) may be downloaded and rates may be filled appropriately. Further you may refer to the "Instructions to Bidders for online participation" document for any portal related issues or contact: 011-49606060, 9355030617 and 9355030630.

3- As per Rule 170 of General Financial Rules (GFRs) 2017, Micro and Small Enterprises (MSEs) and the firms registered with concerned Ministries/ Departments are exempted from submission of Bid Security/EMD. Instead bidders have to submit duly signed "Bid Security Declaration" As per attached Format Annexure-III accepting that if they withdraw or modify their bids during period of validity etc., they will be suspended for the time specified in the tender documents.

4- Please quote the basic rate exclusive of GST and other Taxes (i.e. mention basic rate, GST, freight, taxes separately). Also confirm that documents will be issued for claiming CENVAT.

5- Any product / item / Machine or equipment found faulty during our manufacturing process / system Testing / installation and commissioning / operation of our equipment in field due to deviation from our specifications shall be replaced by vendor free of cost immediately.

Contd..(2)

6- Bid shall remain valid for 150 days.

7- Last date of Clarification: - The last date of seeking any clarification regarding bid is 04/06/2021.

8- Payment Terms:

1- 95% payment through RTGS after receipt of material at ITI LTD-Store.

Balance 5 % will be released against submission of Bank guarantee of same amount for warrantee period.

9- Terms of Price: FOR ITI Limited Rae Bareli

As per govt. norms, while making payment 2.5 Lacs & above, 2% GST TDS will be deducted

10-The above enquiry is also available on the website www.itilttd.in, www.eprocure.gov.in for view purpose and for participation & submission on <https://itilttd.euniwizarde.com> only.

11-Please confirm scope of working and Machine specification strictly as per our Bid Document & Technical Specification which is a part of this bid, in your quotation.

12-Any product / item / Machine or equipment found faulty during our manufacturing process / system testing / installation and commissioning shall be replaced by vendor free of cost immediately.

13-Warranty will be for a period of minimum two years (02) from the installation, commissioning and successful running of the tendered Machines. Any breakdown during warranty period shall attended by the vendor free of cost within 48 hours of informing the complaint & replace the parts, if required, at his own expenses.

14-Bidders should mention their Profile like Name of Firm, Office & Work Address, Fax, Phone, Email ID, Contact Person, Category of Firm (Small/Medium/Large, Dealer, Distributor & Manufacturer etc), Company Registration No., Year of establishment.

15-Bidders should provide their company's Income Tax Permanent A/C No., TIN No., GSTIN No.etc

16-The packing, unpacking, loading and unloading of items shall be done by the bidder at their Expense

17-All suits shall be instituted in a court of competent jurisdiction at Raebareli and in case of arbitration, the Indian Arbitration Act,1996 is applicable

18-ITI Ltd, Raebareli without prejudice to any other remedy for breach of contract, by written notice of default, sent to bidder, terminate this contract in whole or in part, if bidder fails to deliver any or all of the goods within the time period, specified in the contract satisfactorily.

19-ITI Ltd, Raebareli reserve the right to accept or reject any bid, and to annul the bidding process, at any time prior to award of contract without assigning any reason what so ever and without there by incurring any liability to the affected bidder or bidders. ITI Ltd, Raebareli also reserve the right to decrease the quantity to be procured against this tender.

20-Details of Independent External Monitor (IEM) appointed by ITI for Integrity Pact are as under:- Shri Javeed Ahamad, IPS (Retd.),M-1101, Shalimar Gallant Apartment, Vigyanpuri, Mahanagar, Lucknow-226006

21-Integrity Pact (as per format attached) on plain paper duly signed should be submitted along with Technical Bid/Tender Document, online.

22-Bidders participating in E Tendering have to sign Integrity Pact on placement of order/contract.

23-Successful bidder has to sign Integrity Pact on Rs.100/- Stamp Paper if a Purchase Order is placed.

24-If bidder is MSME industry, latest certificate must be provided along with the quotation indicating the class i.e. Women/SC, ST etc.

25-Tendering Processing and Opening

26-Technical Bid will be opened online at 10:30 Hrs on 15/06/2021.

27-Price Bids of only those bidders found technically fulfilling the eligibility conditions and found technically acceptable shall be opened on line on a date to be intimated later.

28-Price bids of those bidders who are found technically ineligible will not be opened and EMD deposited by such bidders if any shall be refunded.

29-Complete sets of NIT documents(List given at (e) below) in Original form duly signed using sign-in process and digital signature by the bidder on each page of the tender documents as a token of having acceptance its contents. Power of Attorney has to be provided in case, the tender documents are signed by an authorized representative.

(30) List Of NIT documents:-

- Bid Document
- Technical Specification (Annexure-I)
- General Specification
- General Requirement (Annexure-II)
- Integrity Pact RB
- Price bid_ Format
- Bid Security Declaration

31-ITI reserves the right to reject any or all the tenders without assigning any reason thereof.

32-Tender in which any of the particulars and prescribed information is missing or are incomplete in any respect, are liable to be rejected.

33-Canvassing of any kind is strictly prohibited and the tender submitted by the bidder who resorts to canvassing is liable for rejection.

34-No part of the tender document shall be removed or altered and the whole set as mentioned thereof, must be submitted after being duly filled in and submitted using sign in process and digital signature. Failure to comply with these instructions may result in the rejection of the tender.

35-The bidder should quote for the entire Scope of Work.

36-The tender submitted by the bidder shall remain valid for a period of 150 days from the date of opening the price bid. Upon acceptance, the rates shall remain firm without any escalation on any account whatsoever till the execution of the project in full.

37-The Request for Quotation with its all enclosures and annexures shall form integral part of the contract / PO.

Bid acceptance

(a) Offers received from the bidders who are failing to meet the eligibility criteria and deviation from the NIT conditions will not be considered.

STATUTORY LEVIES:

All applicable statutory levies like GST etc. should be separately indicated with the current rate applicable. Otherwise rate quoted will be deemed as inclusive of taxes / levies. Vague terms like "As applicable at the time of supply" should be avoided. Apart from statutory levies other charges like handling, P&F etc., will not be paid by us. In case of GST exempted delivery, authorization letter from the competent authority should be enclosed along with the quote.

In case of statutory levies like GST, Surcharge etc., are modified the same has to be intimated to ITI immediately.

MODVAT RELIEF:

We are eligible to avail the credit of GST paid on items procured for manufacturing Tele-communication equipment's under GST RELIEF scheme. Hence "Invoice Cum Gate Pass" in original for payment, and transporter copy duly marked and authenticated is to be produced along with the consignment. In case of your failing to adhere to this instruction, no GST will be reimbursed by us.

Invoices should be in the prescribed form and have all particulars as per GST Rules and notifications as amended from time to time,

Agents/Distributors, on whom an order is placed should also produce Invoice Cum Gate Pass as per the procedure laid down by GST Rules and notifications issued from time to time. They should get registered with GST authorities where GST is being passed on.

INSPECTION:

Inspection of the material at our works will be final. ITI reserves the right to inspect the material at any other standard testing center authorized by us.

GENERAL:

We reserve the right to accept or reject any or all offers and to order full or part quantities or cancellation thereof without assigning any reason whatsoever.

Successful tenderer only will be intimated by post through/letter/mail of intent/firm orders.

Canvassing by tenderers in any form including un-solicited letters against tenders submitted or post-tender corrections shall render their tenders liable for summary rejection.

DELIVERY SCHEDULE:

Shipments must be made strictly as per the indicated delivery schedule in the purchase order.

Liquidated Damages Clause:

Time is the essence of contract and the materials, against an order arising out of this enquiry must be delivered by the supplier according to the delivery schedule indicated in the P.O. In case of any change, the supplier should inform us in advance and obtain our approval to the revised delivery schedule. Should the supplier fail to deliver the material or part thereof as per the delivery schedule, or any

(4)

extension thereof, we shall be entitled at our option either to recover from the supplier, as penalty, a sum equivalent to ½% (half percent) per week for first four weeks and 0.7% per week thereafter for such delay or part thereof or terminate the contract in respect of the balance supply so delayed and purchase materials elsewhere at the risk and cost of the defaulting supplier.

LOCAL REPRESENTATION:

Please indicate your local representative's address, telephone, Fax No., E-mail Id, the person to be contacted, in the offer.

TECHNICAL CATALOGUE:

In the event of any change in the technical catalogue, updated version may be sent to us immediately. It is essential that you simultaneously take up the same with approving authority and their approval copy sent to us.

GOVERNING LAW:

All suits shall be instituted in a court of competent jurisdiction at Rae Bareli and in case of arbitration, the Indian Arbitration Act, 1996 is applicable.

In case of any ambiguity in the bid, decision of ITI Limited Management shall be final.

Chief Manager (PPM)-I
ITI Limited Raebareli
Sultanpur Road , Raebareli -(U. P.)-229010

ANNEXURE-1**Enq No- ESW18E1366CL****Technical Specifications – LT Distribution Panel**

Scope – Design, fabrication and supply of LT Distribution Panels for providing 415 Volt, 3 Phase, 50 Hz, 4 wire supplies as per details mentioned below.

(1) LT Distribution Panel with Three Air Circuit Breaker (ACB) at Input and Two Air Circuit Breaker (ACB) at output [required for Parallel connection of three nos. of 400 KVA UPS]

Quantity – One (01) no.

Specifications –

- i) The Incomer of the panel should consists of the following –
 - 800 Amp Manual Draw Out Type Air Circuit Breaker (ACB), 415 Volt, 50 Hz, 4 Pole, Breaking Capacity 50 KA (minimum), Overload & Short-Circuit Protection, Electronic / Thermo Magnetic Release, suitable spreader at input & output, built in 7 NO +7 NC ACB Auxiliary Contacts for indications with suitable charging handle and ON-OFF switch. The ACB should be Load Line Interchangeable. **- Three (03) nos.**
- ii) The outgoing of the panel should consists of the following –
 - 1250 Amp Manual Draw Out Type Air Circuit Breaker (ACB), 415 Volt, 50 Hz, 4 Pole, Breaking Capacity 50 KA (minimum), Overload & Short-Circuit Protection, Electronic / Thermo Magnetic Release, suitable spreader at input & output, built in 7 NO +7 NC ACB Auxiliary Contacts for indications with suitable charging handle and ON-OFF switch. The ACB should be Load Line Interchangeable. **- Two (02) nos.**
- iii) All the ACB's in the panel shall have the following arrangement -
 - R, Y, B phase indicator with protection
 - ACB Trip Indicator
 - ACB On-Off Indicator
 - VIF Meter (Digital)) with suitable CT's
- iv) Single Line Diagram (SLD) of required Panel is as below (for reference only) –

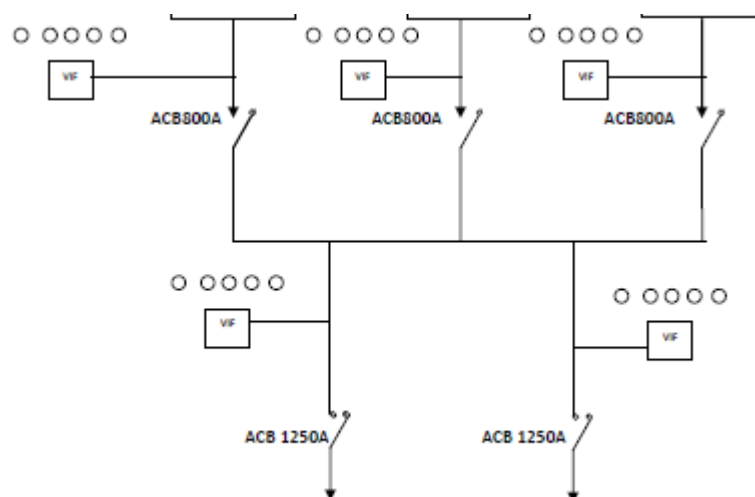

(2) LT Distribution Panel with One Air Circuit Breaker (ACB) at Input and Six (06) MCCB's at output [required for AC Power Distribution]

Quantity – Two (02) nos.

Specifications –

- i) The Incomer of the panel should consists of the following –
- 1250 Amp Manual Draw Out Type Air Circuit Breaker (ACB), 415 Volt, 50 Hz, 4 Pole, Breaking Capacity 50 KA (minimum), Overload & Short-Circuit Protection, Electronic / Thermo Magnetic Release, suitable spreader at input & output, built in 7 NO +7 NC ACB Auxiliary Contacts for indications with suitable charging handle and ON-OFF switch. The ACB should be Load Line Interchangeable. **- One (01) no.**
 - R,Y, B phase indicator with protection
 - ACB Trip Indicator
 - ACB On-Off Indicator
 - VIF Meter (Digital)) with suitable CT's
- ii) The outgoing of the panel should consists of the following –
- 400 Amp MCCB, 415 Volt, 50 Hz, 4 Pole, Breaking Capacity 35 KA minimum, Adjustable Overload Setting, Adjustable Short-Circuit Setting, Electronic / Thermo Magnetic Release, with suitable spreader and extended rotary handle. **- Two (02) nos.**
 - 250 Amp MCCB, 415 Volt, 50 Hz, 4 Pole, Breaking Capacity 35 KA minimum, Adjustable Overload Setting, Adjustable Short-Circuit Setting, Electronic / Thermo Magnetic Release, with suitable spreader and extended rotary handle. **- One (01) no.**
 - 160 Amp MCCB, 415 Volt, 50 Hz, 4 Pole, Breaking Capacity 35 KA minimum, Adjustable Overload Setting, Adjustable Short-Circuit Setting, Electronic / Thermo Magnetic Release, with suitable spreader and extended rotary handle. **- One (01) no.**
 - 100 Amp MCCB, 415 Volt, 50 Hz, 4 Pole, Breaking Capacity 25 KA minimum, Adjustable Overload Setting, Adjustable Short-Circuit Setting, Electronic / Thermo Magnetic Release, with suitable spreader and extended rotary handle. **- Two (02) nos.**

Note – All the MCCB must be 4 Pole with Neutral First make and Last Break Type (Neutral must be marked on the MCCB)

- iii) Single Line Diagram (SLD) of required Panel is as below (for reference only) –

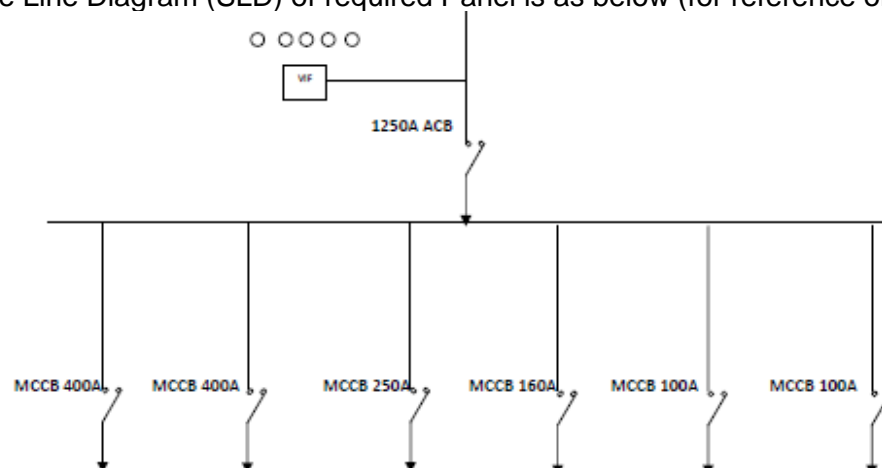

General Specifications for both types of Panels -

- i) The Distribution Panels shall be Indoor Type, Base Mounted with ground clearance of approx. 300 mm along with angle frame (40 x 5 mm) and provision of grouting.
- ii) Panel shall be duly powder coated in Siemens gray colour.
- iii) Panel shall be compartmentalized and made of 2 mm CRCA sheet steel of load bearing and 1.6 mm of non load bearing. Every compartment shall be equipped with lock and key arrangement.
- iv) All the interconnections inside the panel for different switchgears shall be with suitable sizes of bus bars only. Minimum size of the bus bars shall be calculated as 1 Amp = 1 Sqmm. All the bus bars shall be with colour coding bus bar sleeves and shall be supported with Bakelite.
- v) All bus bar nut-bolts shall be cadmium coated and minimum M12 of 5.6 grades or better.
- vi) Bus Bar chamber shall be properly covered with Bakelite to prevent contact accident.
- vii) All the control MCBs shall be wired with suitable sizes of flexible wire.
- viii) All insulators used in the panel shall be non hygroscopic.
- ix) All the ACB / MCCBs shall be mounted in suitable size of panel.
- x) Gland plate required at top and bottom.
- xi) Suitable arrangement shall be provided in the Cable Alley Chamber for support of cables.

Make of Switchgears – Havells / C&S Electric / L&T / Schneider / Indo Asian / ABB / Siemens

CM(PPM)-I

ANNEXURE-2

Enq No- ESW18E1366CL

General Requirement – LT Distribution Panel

1. Party shall provide warranty for two (02) years (minimum) from date of supply.
2. Make, Model and full specification of the offered item shall be provided by the party supported by the relevant catalogue / leaflet.
3. Party shall submit a detailed wiring diagram & layout drawing along with dimension of the AC Distribution Panel.
4. The items should comply the related standards where ever applicable.
5. Pre-delivery inspection may be conducted at the vendor's works by ITI representative, if desired.
6. After sales service and spares availability shall be ensured by the party.
7. All the panels shall be taken from single bidder only.
8. The Bidder (Party) must be the OEM or Authorized Vendor of the OEM. Latest Authorization Certificate shall be submitted along with the bid.
9. Party shall provide point wise compliance for Annexure – 1 & 2.

CM (PPM)-1



ITI LIMITED
(A Government of India Undertaking)
Sultanpur Road, RAE BARELI-229010 (U.P)



TENDER FOR LT Distribution Panels AS PER SCOPE OF WORK & TECHNICAL SPECIFICATION & GENERAL REQUIREMENT MENTIONED IN BID DOCUMENT.

Name of Firm

Price Bid format for LT Distribution Panels

A> Offer for LT Panels

SI	Details of the Items	HSN Code	Qty Reqd (1)	Basic Unit Price (in Rs.) (2)	Total Price (in Rs.) (3=1*2)	GST %	Total Price (in Rs.) (with GST)	Total Value with GST and TCS
1	LT Distribution Panel with Three Air Circuit breaker (ACB) at input and Two Air circuit Breaker (ACB) at output.		1		0		0	0
2	LT Distribution Panel with One Air Circuit breaker (ACB) at input and Six(06) MCCB 's at output Air circuit Breaker (ACB) at output.		2		0		0	0

B> Other Terms

1	Terms of Price	FOR ITI Raebareli
2	Payment Terms	95% payment through RTGS after receipt of material at ITI LTD-Store. Balance 5 % will be released against submission of Bank guarantee of same amount for warrantee period.
3	Warranty	2 years from the date of installation & Commissioning of the machine

Note- Any deviation from above format shall be liable for rejection of the bid

